

Einbauanleitung Mounting instruction Montagehandleiding Instructions de montage Istruzioni di montaggio

BED super flach

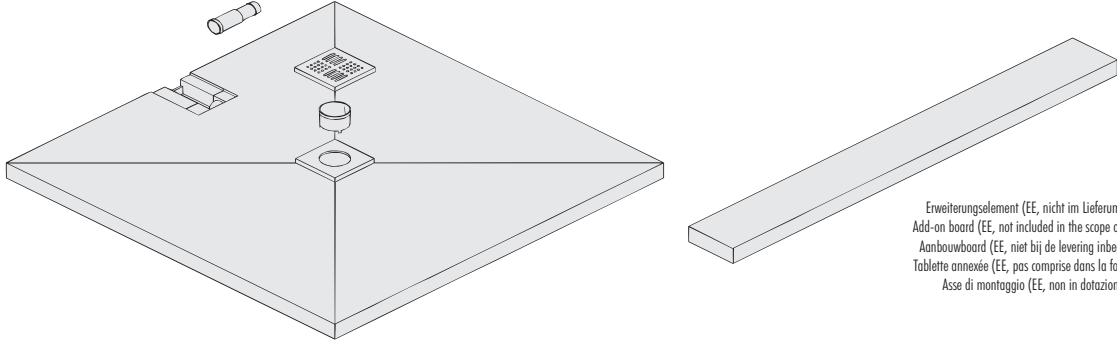

Erweiterungselement (EE, nicht im Lieferumfang)
Add-on board (EE, not included in the scope of supply)
Aanbouwboard (EE, niet bij de levering inbegrepen)
Tablette annexée (EE, pas comprise dans la fourniture)
Asse di montaggio (EE, non in dotazione)

2

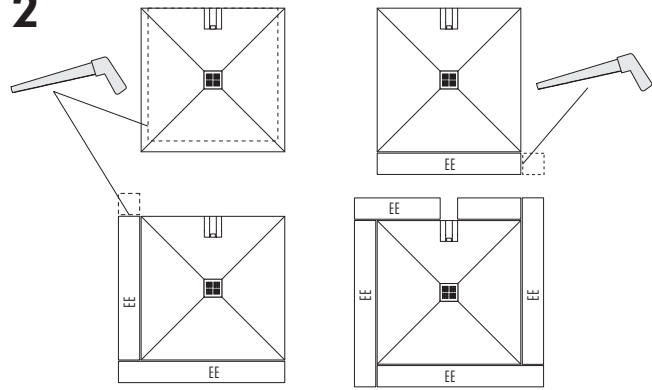

1

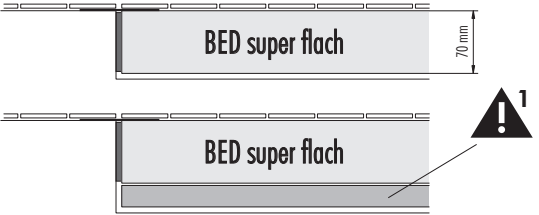
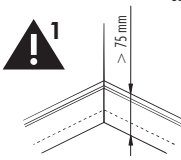
Estrichsokkel - Screed base - Estrikondergrond
Socle de chape - Zoccolo del pavimento continuo

Unterbaulement - Substructure element - Onderbouwlement
Element de support de base - Elemento di spessore

3

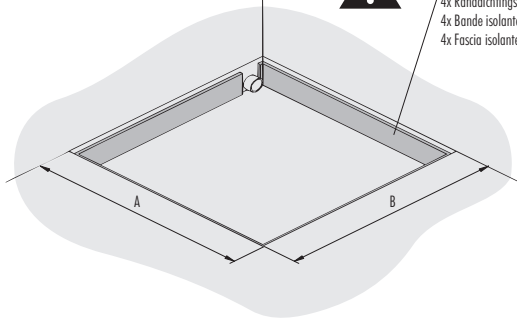

4x Randdämmstreifen
4x Edge insulation strips
4x Randdichtungsstroken
4x Bande isolante de bord
4x Fascia isolante di bordo

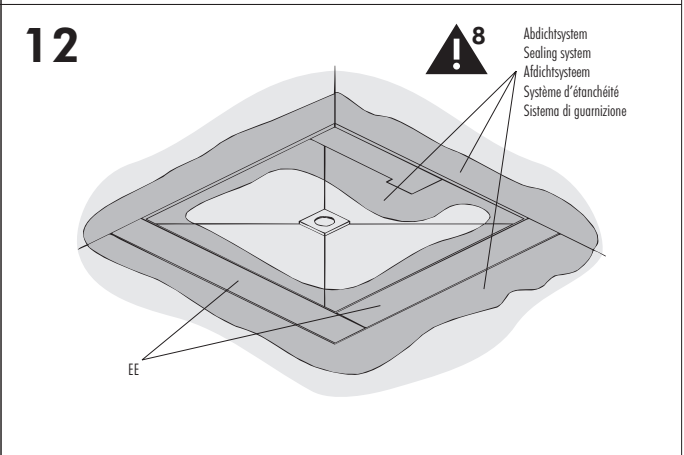
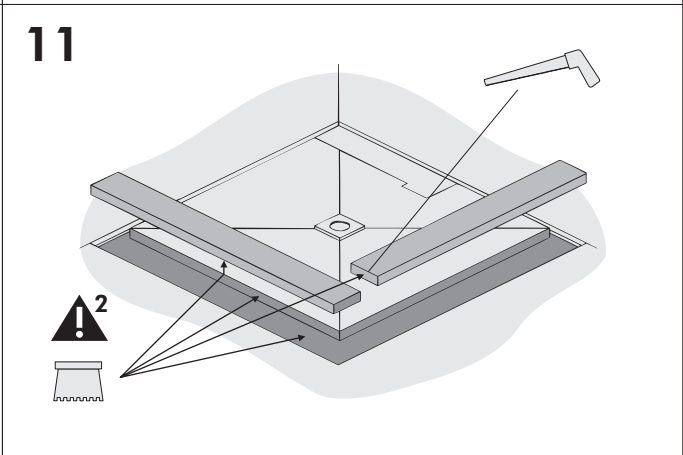
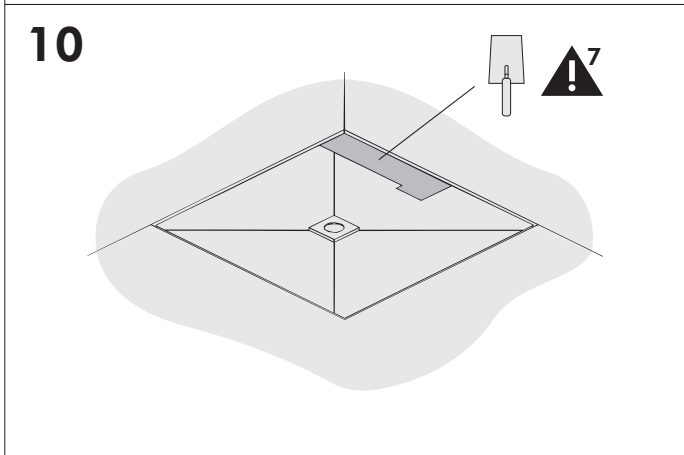
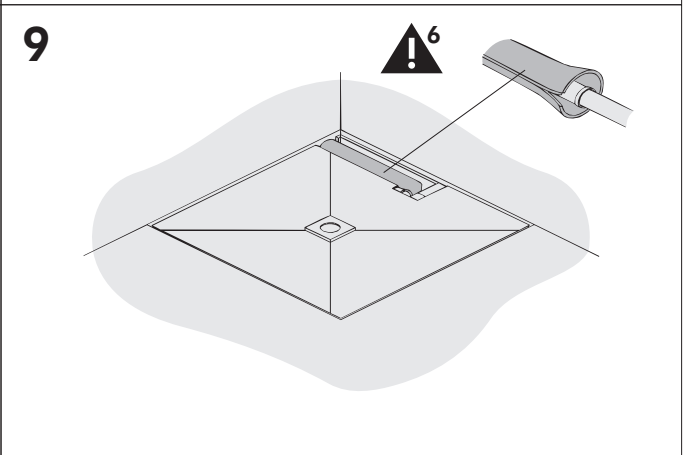
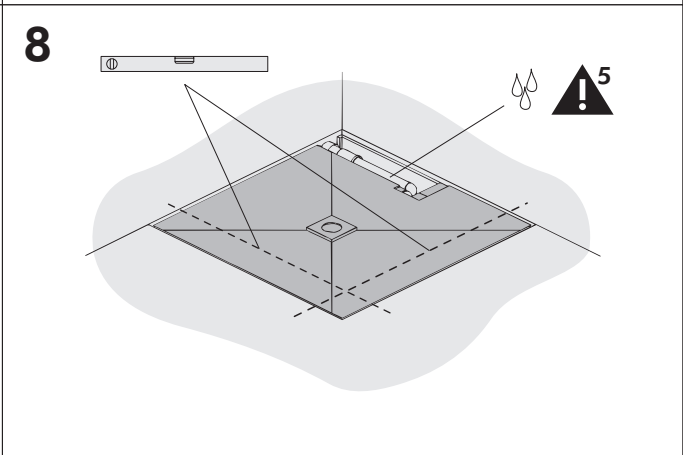
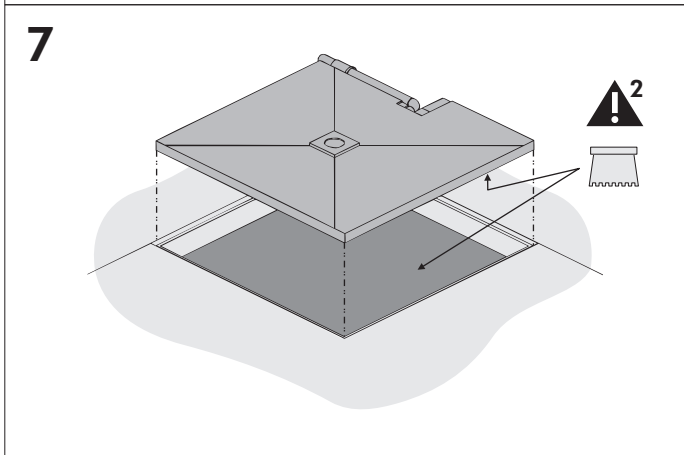
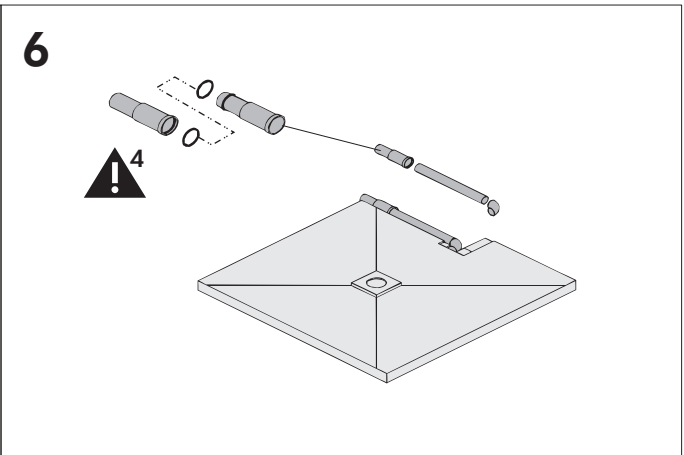
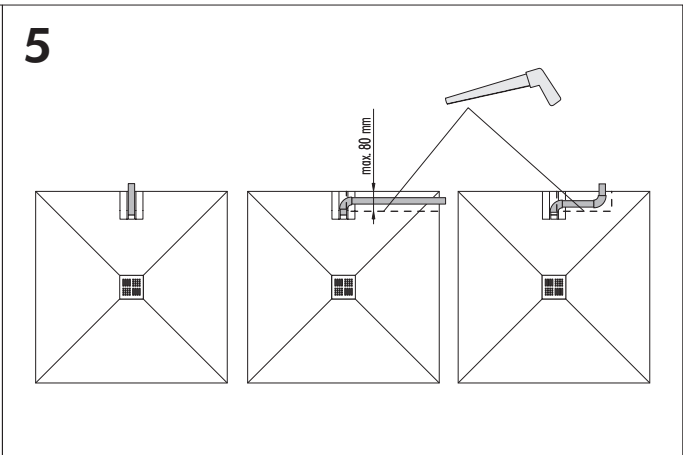
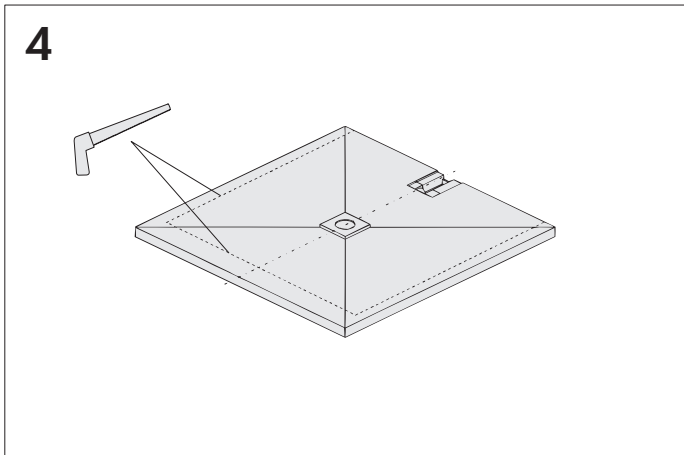

13

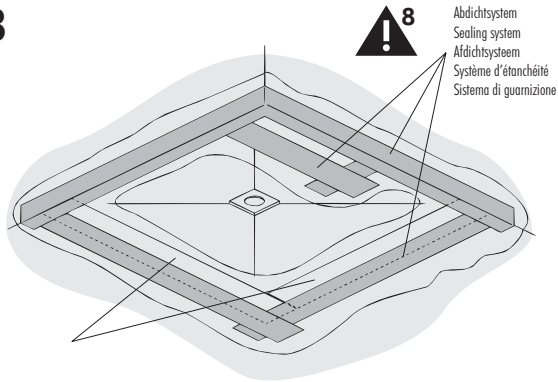

8
 Abdichtsystem
 Sealing system
 Afdichtstysteem
 Système d'étanchéité
 Sistema di guarnizione

14

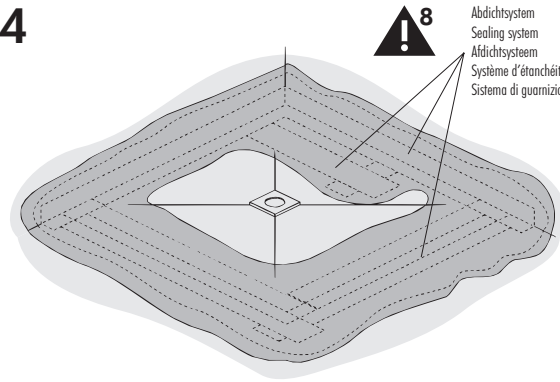

8
 Abdichtsystem
 Sealing system
 Afdichtstysteem
 Système d'étanchéité
 Sistema di guarnizione

15

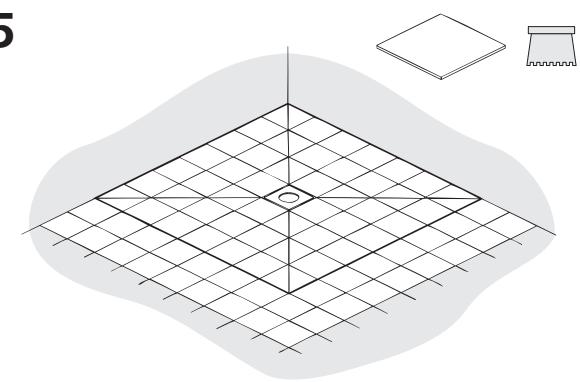

16

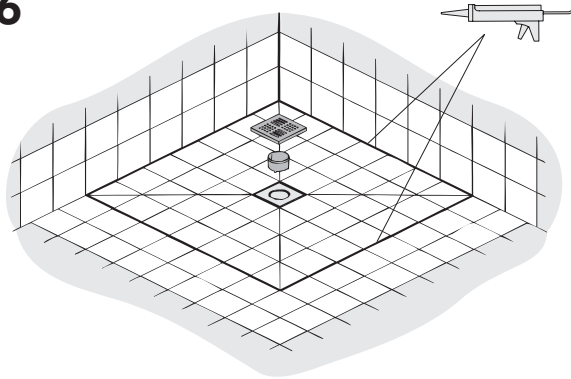

Empfohlenes Zubehör - Recommended accessories -
 Aanbevolen toebehoren - Accessoires recommandés -
 Accessori raccomandati:

Profi-Flex-Schnellkleber
 Profi-Flex fast-setting adhesive
 Profi-Flex-snelplakker
 Colle rapida Profi-Flex
 Collante rapido Profi-Flex

Abdichtsystem
 Sealing system
 Afdichtstysteem
 Système d'étanchéité
 Sistema di guarnizione

Unterbaulement
 Substrate element
 Onderbouwelement
 Élément de support de base
 Elemento di supporto di base

Dichtband
 Sealing tape
 Afdichtingsband
 Bande isolante
 Fascia isolante









Dichtband-Innenecke
 Sealing tape interior corner
 Afdichtingsband-binnenliggende hoek
 Bande isolante pour coin intérieur
 Fascia isolante per angolo interno

Dichtband-Außenecke
 Sealing tape exterior corner
 Afdichtingsband-buitenliggende hoek
 Bande isolante pour coin extérieur
 Fascia isolante per angolo esterno

Silikon
 Silicone
 Siliconen
 Silicone
 Silicone

Verwendung:

- Das Duschsystem BED super flach kann vom Verarbeiter unter Berücksichtigung der Größe, Einbauhöhe und der Geometrie des Duschsystems seitlich und gegenüberliegend zum Ablauf variabel gekürzt werden.
- Für den Einbau des Duschsystems muss ein ebener, sauberer, tragfähiger, schwingungsfreier und für die Verklebung mit Profi-Flex-Schnellkleber geeigneter Untergrund vorhanden sein.
- Das Duschsystem ist generell rollstuhlfahrbar unter Verwendung von Fliesen mit einer Mindestgröße 100 x 100 mm. Bei Einarbeitung eines Glasgewebes in das Fliesenkleberbett können auch Fliesen mit einer Mindestgröße 50 x 50 mm verwendet werden.
- Nur für den Einsatz im Innenbereich geeignet.

-  Die einschlägigen Verarbeitungsrichtlinien aller beteiligten Gewerke sind zu berücksichtigen.
-  Beim Einbau (Estrichhöhe > 75 mm) müssen Unterbauelemente (nicht im Lieferumfang) oder ein gegossener Estrichsockel verwendet werden.
-  Fliesenkleber immer beidseitig auftragen. Werden Erweiterungselemente verwendet, ist Fliesenkleber auch auf den Stirnseiten des BED super flach sowie den Erweiterungselementen aufzutragen.
-  Randdämmstreifen sind bauseits zu stellen.
-  Dichtring von der Steckverbindung entfernen und in die Muffe einsetzen.
-  Nach Installation der Ablaufgarnitur ist eine Dichtigkeitsprüfung durchzuführen.
-  Vor Verschließen des Ablaufkanals eine geeignete Wärme- und Schallschutzummantelung an der Ablaufleitung anbringen.
-  Verschließen des Ablaufkanals mit Fliesenkleber. Den Fliesenkleber standfest anrühren. Die Verarbeitungshinweise des Herstellers sind zu beachten.
-  Die Verarbeitungshinweise des Abdichtsystems sind zu beachten.

Einbaubeispiel mit Unterbauelement:

Aufbauhöhe/Fertigfußboden	100 mm
BED super flach	-70 mm
2 Lagen Fliesenkleber	-10 mm
<hr/> Unterbauelement	<hr/> = 20 mm

Use:

- The shower system BED super flach may be variably cut to size by the installer laterally and opposite of the drain in consideration of the size, the installation height and the geometry of the shower system.
- For the installation of the shower system a level, clean, solid surface free of vibrations and suited for fastening with Profi-Flex fast tile adhesive must be available.
- The shower system is generally accessible for wheel chairs when using tiles of a minimum size of 100 x 100 mm. If glass fabric is worked into the tile adhesive bed, also tiles of a minimum size of 50 x 50 mm may be used.
- Suitable only for use indoor.

 The relevant processing guidelines of all trades involved must be observed.

 For the installation (screed base height > 75 mm), either substructure elements (not included in the scope of supply) or a cast plaster floor base are being used.

 In general, apply tile adhesive to both sides. If add-on boards are used, apply tile adhesive also to the front sides of the BED super flach and to the add-on boards.

 Edge insulation strips shall be provided by the owner.

 Remove sealing ring from the plug-in connection and insert into sleeve.

 After installation of the outlet fitting, a leak test is to be performed.

 Before closing the drain duct apply a suitable thermal and acoustic protective sheathing to the drain line.

 Close the drain duct with tile adhesive. The tile adhesive should not be too moist after mixing. The processing instructions of the manufacturer shall be observed.

 The processing guidelines of the sealing system are to be observed.

Example for installation with substrate element:

Mounting height/finished floor level	100 mm
BED super flach	-70 mm
2 layers of tile adhesive	-10 mm
<hr/> Substrate element	<hr/> = 20 mm

Toepassing:

- Het douchesysteem BED super flach kan door de monteur afhankelijk van maten, inbouwhoogte en geometrie van het douchesysteem aan de zijkanalen en tegenover de afvoer variabel worden ingekort.
- Voor de montage van het douchesysteem moet een vlakke, schone, draagkrachtige, trivrije en voor verwerking van de Profi-Flex-snelplakker geschikte ondergrond aanwezig zijn.
- Het douchesysteem is in principe voor een rolstoel geschikt, als tegels met een minimale grootte van 100 x 100 mm worden toegepast. Bij verwerking van glasvezelmateriaal in de plakondergrond kunnen ook tegels van minimaal 50 x 50 mm worden gebruikt.
- Alleen geschikt voor toepassing in binnenruimte.

 Met de betreffende toepassingsrichtlijnen van alle betroffen onderdelen moet rekening worden gehouden.

 Bij inbouw (estriekhoogte > 75 mm) moeten onderbauelementen (niet in levering inbegrepen) of een gegoten estriekondergrond worden toegepast.

 Tegelplakker altijd aan beide kanten aanbrengen. Wanneer er aanbouwboards worden gebruikt, moet er ook tegelplakker op de kopkanten van de BED super flach en op de aanbouwboards worden aangebracht.

 Randdichtingsstroken zijn niet in de levering inbegrepen.

 Dichtring van de steekverbinding wegnemen en in de mof plaatsen.

 Na de installatie van de afvoergarnitur moet de dichtheid worden getest.

 Vóór afsluiten van het afvoerkanaal een geschikte warmte- en geluidsisolatiemantel aan de afvoerleiding aanbrengen.

 Het afvoerkanaal met tegelplakker afsluiten. Tegelplakker niet te dun aanroeren. De verwerkingsaanwijzingen van de fabrikant in acht nemen.

 Met de betreffende toepassingsrichtlijnen van afdichtstelsysteem moet rekening worden gehouden.

Montagevoorbeeld met onderbauelement:

Opbouwhoogte/douchebak	100 mm
BED super flach	-70 mm
2 lagen tegelplakker	-10 mm
<hr/> Onderbauelement	<hr/> = 20 mm

Utilisation:

- Le système de douche BED super flach peut être raccourci par l'installateur de manière variable à côté et en face de la conduite d'écoulement, et ceci en tenant compte des dimensions, de la hauteur de montage et de la géométrie du système de douche même.
- Pour l'installation du système de douche, il est nécessaire de disposer d'une surface de base plane, propre, capable de porter le système, antivibratoire et appropriée à l'application de la colle rapide Profi-Flex.
- En général, le système de douche permet l'accès en fauteuil roulant à la condition de poser des carreaux d'une dimension minimale de 100 x 100 mm. Si le lit de pose des carreaux est renforcé par un tissu de fibres de verre, il est possible d'utiliser également des carreaux d'une dimension minimale de 50 x 50 mm.
- Ne se prête qu'à l'installation à l'intérieur de bâtiments.

 Observer attentivement les différents pas.

 Lors de l'installation (hauteur de chape > 75 mm), il faut utiliser des éléments de support de base (pas compris dans la fourniture) ou un socle coulé de chape.

 Appliquer la colle à carrelage toujours sur les deux faces. En cas d'utilisation d'éléments d'extension, appliquer la colle pour carreaux également sur les flancs du BED super flach ainsi que sur les tablettes annexées.

 Les bandes isolantes intérieures sont à fournir par le client.

 Enlever le joint du tube et le placer dans le manchon.

 Après installation du tube d'évacuation d'eau, il faut procéder à un contrôle d'étanchéité.

 Avant de fermer le conduit d'écoulement, veiller à envelopper le conduit et l'insonoriser.

 Fermeture du conduit d'écoulement par de la colle pour carreaux. Préparer la colle de manière à obtenir une consistance assez solide. Observer les directives de mise en œuvre du fabricant.

 Il faut respecter les instructions de mise en oeuvre du système d'étanchéité.

Exemple d'installation avec élément de support de base:

Hauteur de montage/sol fini	100 mm
BED super flach	-70 mm
2 couches de colle pour carreaux	-10 mm
<hr/> Élément de support de base	<hr/> = 20 mm

Uso:





- Il sistema doccia BED super flach può essere accorciato dall'installatore in considerazione della grandezza, dell'altezza d'installazione e della geometria del sistema doccia lateralmente e di fronte allo scarico in modo variabile.
- Per l'installazione del sistema doccia deve esistere un sottosuolo piano, pulito, solido, libero di vibrazioni e adatto per l'incollaggio per mezzo del collante rapido Profi-Flex.
- Il sistema doccia è generalmente accessibile con sedia a rotelle, se piastrelle di una grandezza minima di 100 x 100 mm sono usate. Ad integrazione di un tessuto di vetro nel letto d'incollaggio piastrelle anche piastrelle di una grandezza minima di 50 x 50 mm possono essere usate.
- Adatto solo per l'uso in locali chiusi.

 Si deve osservare le istruzioni corrispondenti di lavorazione di tutti i mestieri partecipanti.

 All'installazione (altezza del pavimento > 75 mm), si deve utilizzare elementi di supporto di base (non compresi nella fornitura) o uno zoccolo colato di pavimento.

 Applicare l'adesivo per piastrelle sempre su entrambi i lati. Se si utilizzano assi di montaggio, l'adesivo per piastrelle deve essere applicato anche sui fianchi del BED super flach e sugli assi di montaggio.

 Le fasce isolanti di bordo sono da fornire dal cliente.

-  **4** Togliere l'anello di tenuta dal collegamento ad innesto e metterlo nel manicotto.
-  **5** Dopo aver installato il gruppo di scarico è necessario eseguire un controllo della tenuta.
-  **6** Prima di chiudere il canale di scarico, la condotta di scarico è da munire di un rivestimento termoisolante ed insonorizzante appropriato.
-  **7** Chiusura del canale di scarico con adesivo per piastrelle. Preparare l'adesivo in modo da ottenere una consistenza assai solida. Si devono osservare le istruzioni di lavorazione del fabbricante.
-  **8** Si deve osservare le istruzioni di lavorazione del sistema di guarnizione.

Esempio d'installazione con elemento di supporto di base:

Altezza di montaggio/ pavimento finito	100 mm
BED super flach	-70 mm
N. 2 strati di collante per piastrelle	-10 mm
Elemento di supporto di base	= 20 mm