



KRAFTSTOFFMANAGEMENT-SYSTEM



ABGABEEINHEITEN



KITS



PUMPEN



ZÄHLER



ZAPFVENTIL

K24

MERKMALE

- BERSTDRUCK 100 BAR
- LCD-DISPLAY
- VOLUMENSTROMANZEIGE
- EINFACH KALIBRIERBAR

Der PIUSI K24 ist ein speziell für Diesel entwickelter digitaler Turbinen-Volumenstrommesser. Er lässt sich einfach in der Leitung oder am Ende eines Versorgungsrohrs installieren und ist mit einem drehbaren Display ausgestattet. Dieses Messgerät ist sowohl mit Aluminium- als auch mit Technopolymer-Gehäuse erhältlich.

LEISTUNGSPARAMETER

7-120

L/MIN

VOLUMENSTROM

20 BAR

MAX

BETRIEBSDRUCK

± 1%

GENAUIGKEIT

0,2%

REPRODUZIERBARKEIT



K24 IN KUNSTSTOFFAUSFÜHRUNG



K24 PULSER

K24

VERPACKUNG

CODE	GEWICHT		VERPACKUNG		
	KG	LBS	MM	ZOLL	STCK./KARTON
K24					
FOO40700A	0,5	1,1	BLISTER	BLISTER	1
FOO408100	0,5	1,1	BLISTER	BLISTER	1
K24 PULSER					
FOO40722A	0,5	1,1	115X16OX135	4,5X6,3X5,3	1



FILTERUNG



TANKÜBERWACHUNG



SCHLAUCHAUFRÖLLER



ZUBEHÖR



MERCHANDISE



LUFT



FROSTSCHUTZ



AdBlue®



BIODIESEL



DIESEL



LEBENSM.



BENZIN



SCHMIERM.



KEROSIN



ÖL



WASSER



WISCHERFLÜSS.

KENNLINIEN

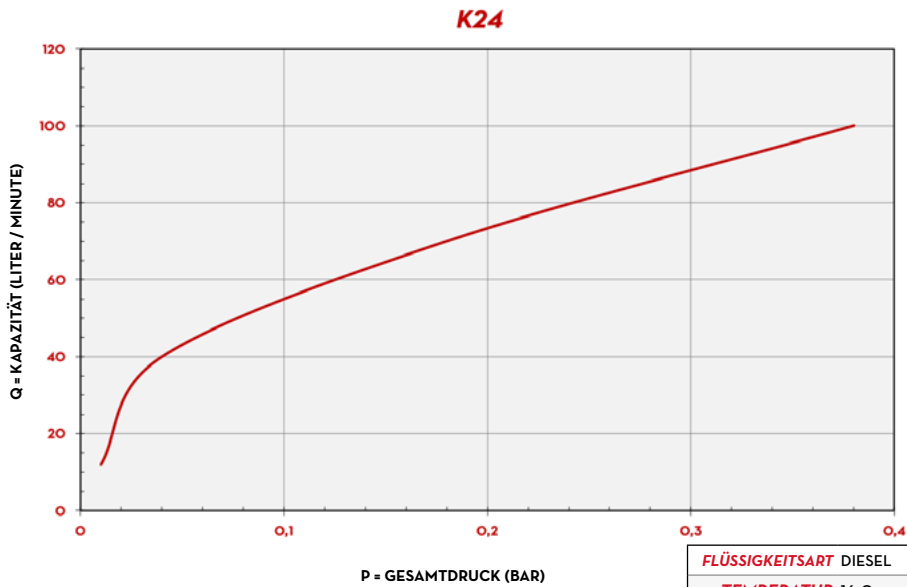

ABMESSUNGEN

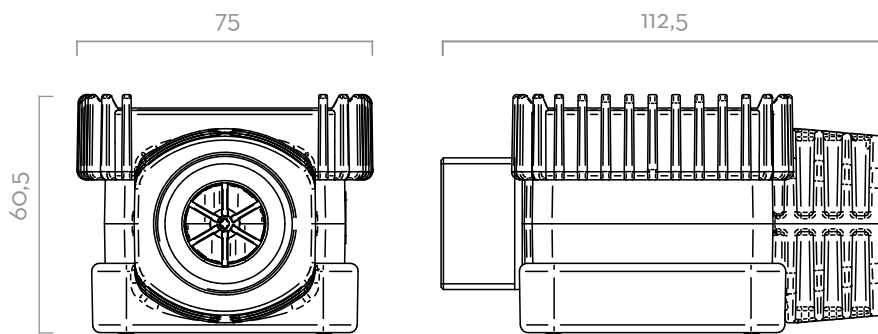

Maße in Millimetern

LIEFERUMFANG

- ZÄHLER K24
- BEDIENUNGSANLEITUNG
- F/F-BUCHSE

EINZELHEITEN



MATERIALIEN

- GEHÄUSE: ALUMINIUM
- ZAHNRÄDER: TECHNOPOLYMER

TECHNISCHE DATEN

CODE	BESCHREIBUNG	FLÜSSIGKEITSART	VOLUMENSTROM		DRUCK		BATTERIE 2X AAA BATTERIE 1,5V (INCLUDE)	FLANSCH	EINLASS/AUSLASS
			L/MIN	GPM	BAR	PSI			
K24									
FOO40700A	K24 METER M/MF LITER BLACK 1INBSP	D	7 - 120	2 - 32	10	150	JA	NEIN	M 1" BSP - M 1" BSP
FOO408100	K24 M/F 1" BSP	D	7 - 120	2 - 32	20	300	JA	NEIN	M 1" BSP - F 1" BSP
K24 PULSER									
FOO40722A	K24 PULSER M/MF LITER BLACK 1INBSP	D	7 - 120	2 - 32	10	150	NEIN	NEIN	M 1" BSP - M 1" BSP

AUF ANFRAGE ALS NPTF-AUSFÜHRUNG UND MIT ANZEIGE IN GALLONEN/QUARTERN BZW. PINT ERHÄLTlich * N = 2 1,5-V-BATTERIEN MITGELIEFERT

K24