

802341

Montage- und Serviceanleitung  
Instructions de montage et d'entretien  
Istruzioni di montaggio e di assistenza  
Instrucciones de montaje y servicio  
Installation and service instructions

Armaturen für die Grossküche  
Robinetterie pour cuisines commerciales  
Rubinetteria per grandi cucine  
Grifferia para cocina profesional  
Faucets for the commercial kitchen

Hebelmischer  
Mitigeur à levier  
Miscelatore  
Mezclador  
Faucet with lever handle

KWC GASTRO

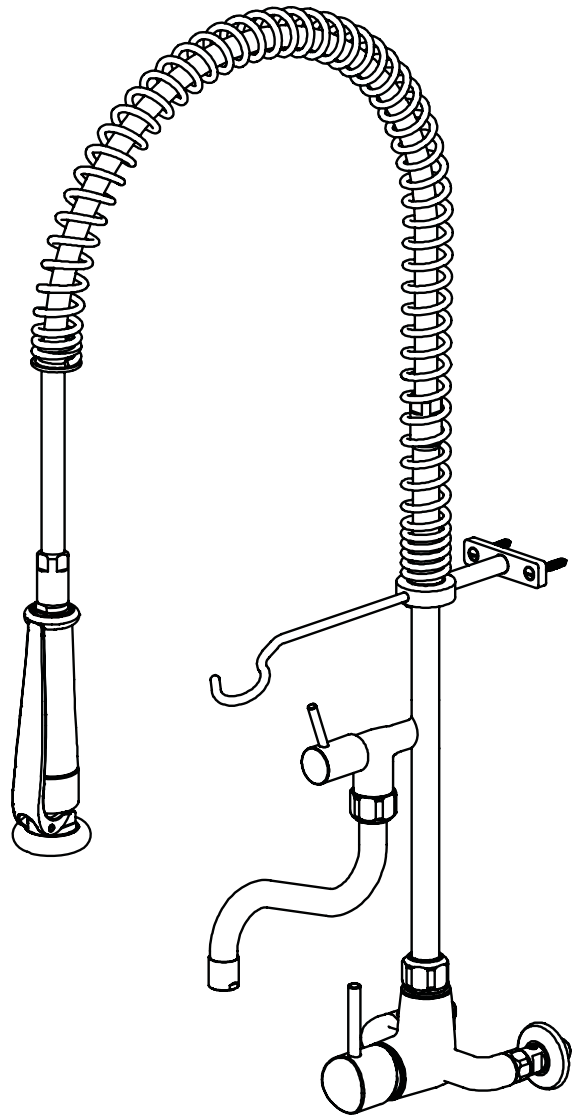
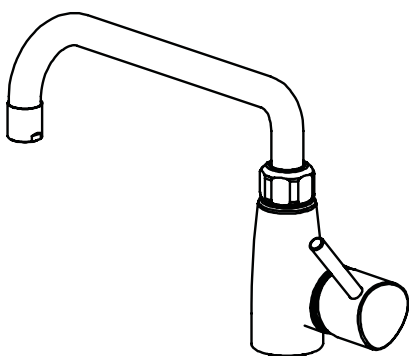

Idealer Betriebsdruck : 3 bar  
 Max. Betriebsdruck : 5 bar  
 Min. Betriebsdruck : 1 bar  
 Druckgleichheit empfehlenswert.  
 Ideale Wassertemperatur : 60 °C  
 Max. Wassertemperatur : 80 °C

Presión ideal de servicio : 3 bar  
 Presión máxima de servicio : 5 bar  
 Presión mínima de servicio : 1 bar  
 Se recomienda la igualdad de las presiones.  
 Temperatura ideal del agua : 60 °C  
 Temperatura máxima del agua : 80 °C



Achtung:  
 Vor Montage die Leitungen gründlich durchspülen!



Atención:  
 Enjuagar escrupulosamente las tuberías antes del montaje!

Weitere Informationen finden Sie in unseren detaillierten Verkaufsunterlagen.

Información más detallada en nuestra documentación de ventas.

Pressione di servizio ideale : 3 bar  
 Pressione di servizio mass. : 5 bar  
 Pressione di servizio min. : 1 bar  
 Si raccomanda pressioni uguali.  
 Temperatura acqua calda ideale : 60°C  
 Temperatura acqua calda mass. : 80°C

Ideal operating pressure : 3 bar / 45 PSI / 300 kPa  
 Max. operating pressure : 5 bar / 70 PSI / 500 kPa  
 Min. operating pressure : 1 bar / 14.5 PSI / 100 kPa  
 Equal pressures are recommended.  
 Ideal water temperature : 60 °C (140°F)  
 Max. water temperature : 80 °C (180°F)



Attenzione:  
 Risciacquare bene le tubazioni prima del montaggio!



Attention:  
 Flush pipes thoroughly before installation!

Ulteriori informazioni le troverete nelle nostre dettagliate documentazioni.

For further information refer to our detailed sales literature.

Pression de service idéale : 3 bar  
 Pression de service max. : 5 bar  
 Pression de service min. : 1 bar  
 Egalité de pression recommandée.  
 Température idéale de l'eau : 60°C  
 Température max. de l'eau : 80°C



Attention:  
 Rincer à fond la tuyauterie avant le montage!

Pour informations supplémentaires voir nos documentations de vente détaillées.



- D Schäden, die infolge unsachgemässer Behandlung, natürlicher Abnutzung oder zu grosser Inanspruchnahme entstanden sind, sind von unseren Garantieleistungen ausgeschlossen!
- F Ces dommages survenus en raison d'un traitement inadéquat, des signes d'usure traitement inadéquat, naturels ou du grand utilisation, sont exclus de notre garantie.
- I Danni ai rubinetti, conseguenti da un trattamento non appropriato, sono esclusi dalla nostra garanzia!
- Sp Daños, debidos a un tratamiento inadecuado, son excluidos de la nuestra garantía.
- E Damages on the faucet resulting from incorrect handling are excluded from the manufacturers warranty!

Befestigung  
 Fixation  
 Fissaggio  
 Fijación  
 Connection

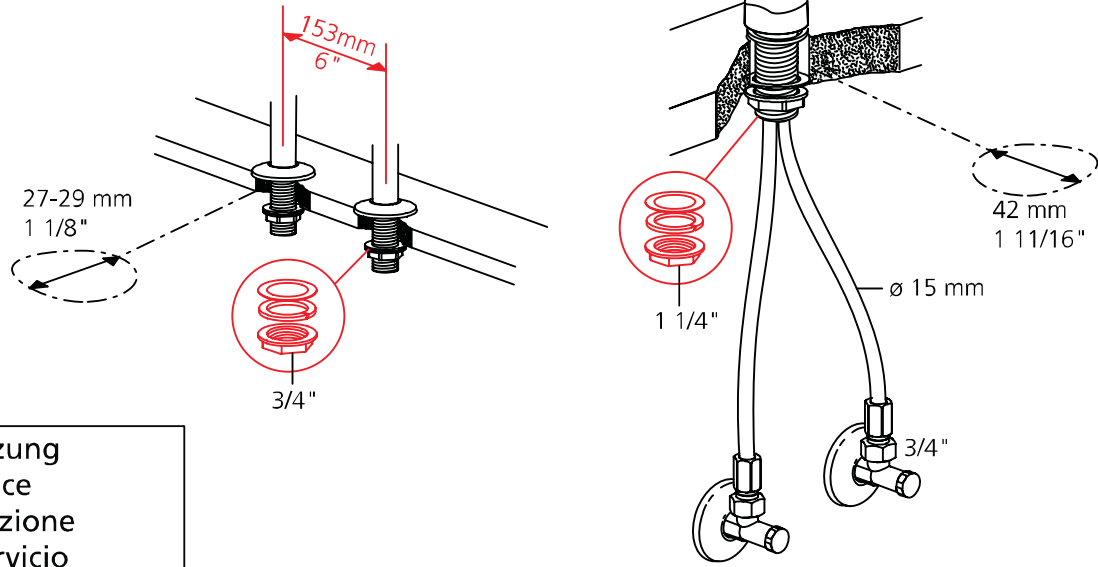

Inbetriebsetzung  
 Mise en service  
 Messa in funzione  
 Puesta en servicio  
 Initial operation

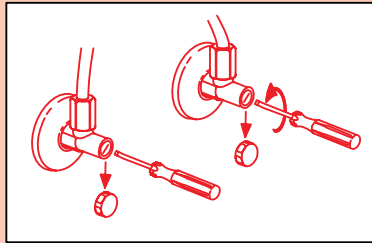
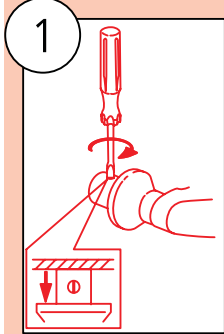

Kalt- und Warmwasser öffnen.  
 Ouvrir eau froide et chaude.  
 Aprire acqua fredda e calda.  
 Abrir la salida de agua fría y caliente.  
 Open cold and hot water.

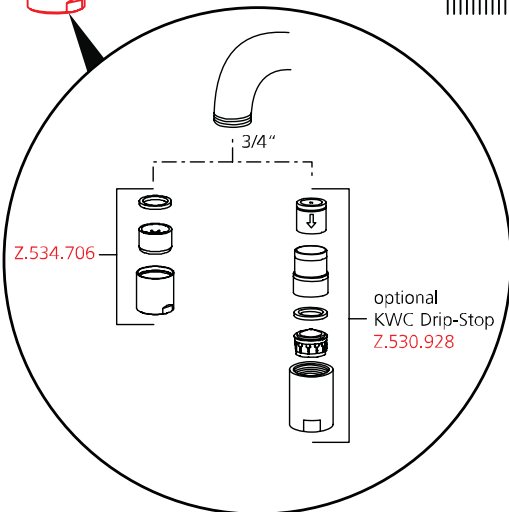
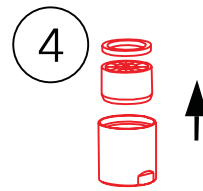
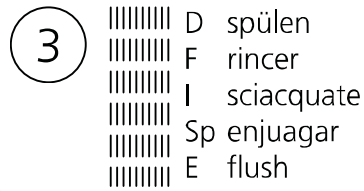
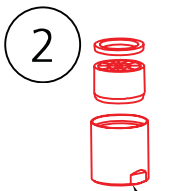
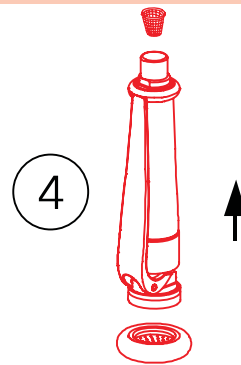
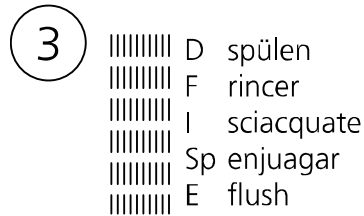
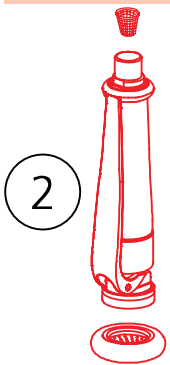

Befestigung Wandhalter  
Fixation support mural  
Fissaggio supporto murale  
Fijación soporte mural  
Connection wall bracket

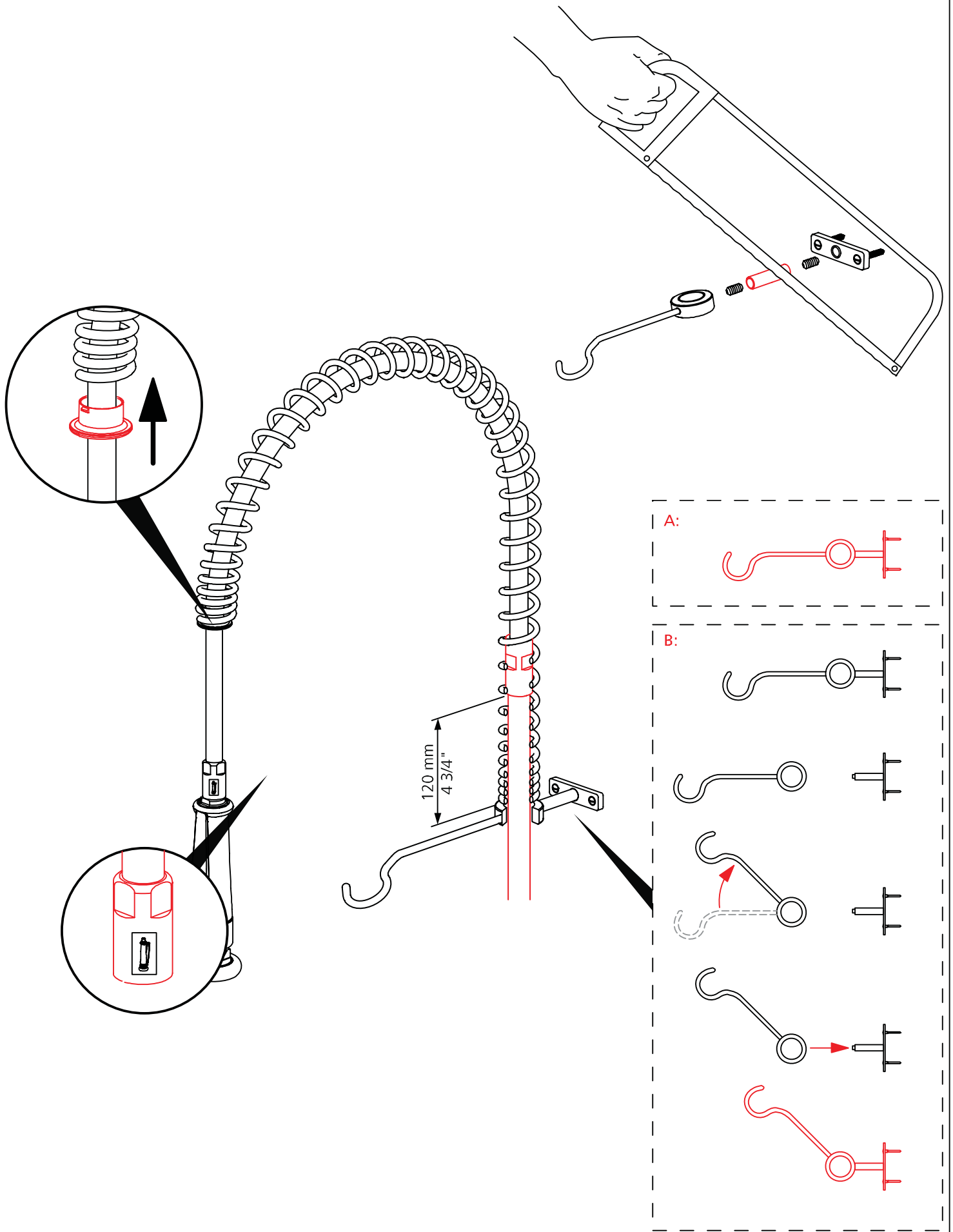

Höchsttemperaturbegrenzung  
 Limitation de la température max.  
 Limitazione della temperatura massima  
 Limitación de la temperatura máxima  
 Maximum temperature limitation

Austausch der Steuerpatrone  
 Remplacement de la cartouche  
 Sostituzione della cartuccia  
 Recambio del cartucho de mando  
 Replacing of the control cartridge

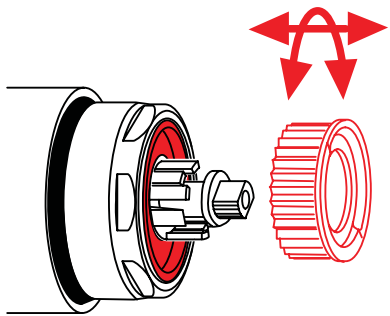

Temperaturring  
 Anneau de limitation  
 Anello di limitazione  
 Anillo de la temperatura  
 Temperature ring

Max. Temperaturbereich :  
 Plage de température max. :  
 Campo di temperatura mass. :  
 Gama de temperaturas máx. :  
 Max. temperature range :

Begrenzter Temperaturbereich :  
 Plage de température réduite :  
 Campo di temperatura ridotto :  
 Gama de temperaturas reducidas :  
 Reduced temperature range :

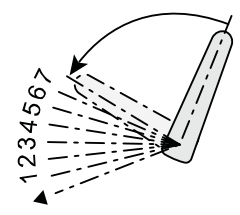
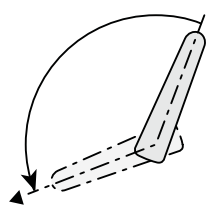
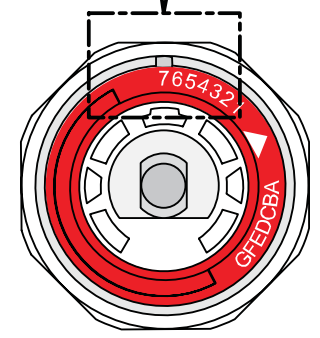
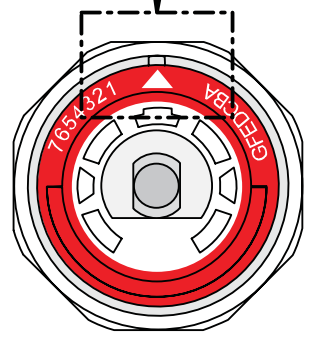
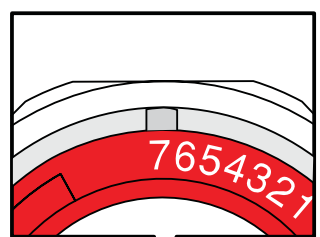
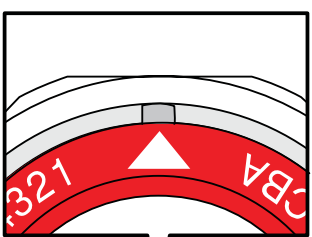

Pfeil auf Kerbe.  
 Flèche sur encoche.  
 Freccia su scanalatura.  
 Flecha en la hendidura.  
 Arrow on groove.

Position 1 - 7  
 Position 1 - 7  
 Position 1 - 7  
 Posición 1 - 7  
 Positions 1 - 7

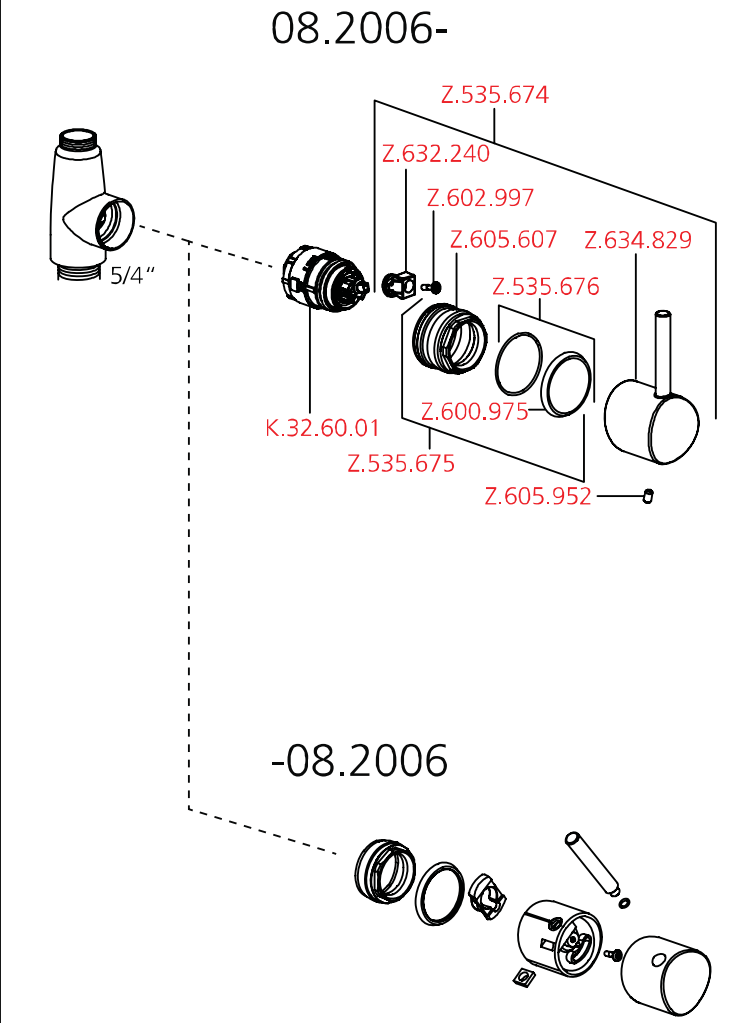

ausgenommen  
 sauf  
 escluso  
 excluido  
 except

K.24.32.11/14

6

Es dürfen ausschliesslich **original Ersatzteile** verwendet werden!

Utiliser seulement des **pièces de rechange originaux!**

Usare soltanto i **pezzi di ricambio originali!**

¡Utilizar solamente los **Requetos originales!**

Only the **original Spare parts** may be used!

Ersatzteile

Pièces de rechange

Pezzi di ricambio

Repuestos

Spare parts

**24.501.044** A 300

**24.501.046** A 400

**24.501.054** A 300 H= 100mm

**24.501.056** A 400 H= 100mm

**24.501.064** A 300 H= 300mm

**24.501.066** A 400 H= 300mm

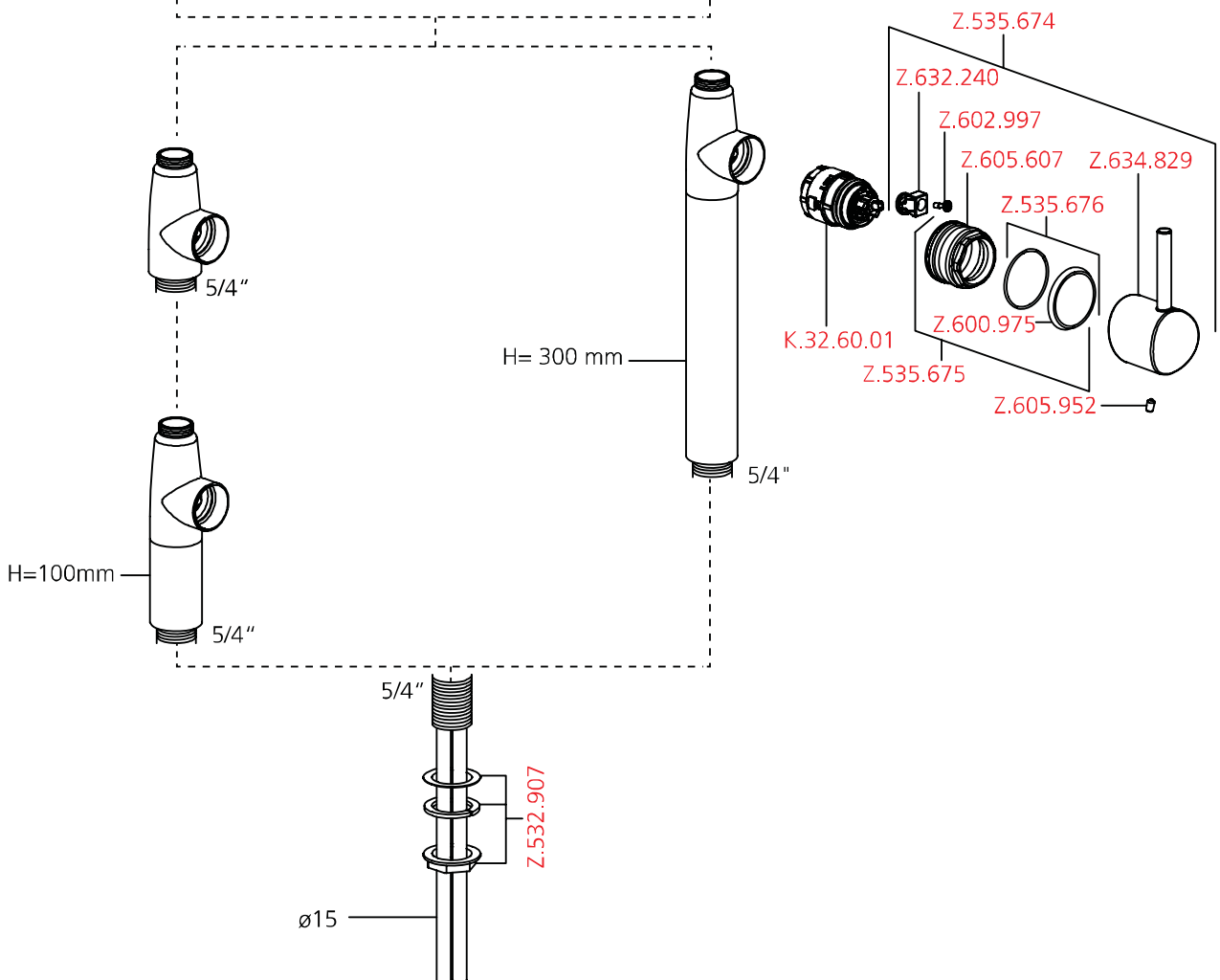
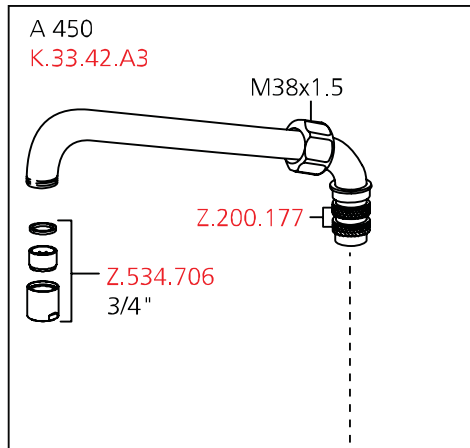
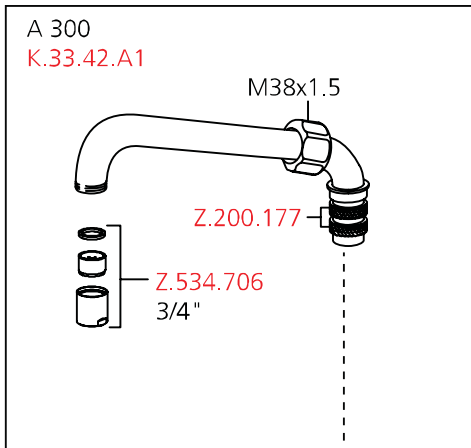

Ersatzteile  
Pièces de rechange  
Pezzi di ricambio  
Repuestos  
Spare parts

Es dürfen ausschliesslich **original Ersatzteile** verwendet werden!  
Utiliser seulement des **pièces de rechange originaux!**  
Usare soltanto i **pezzi di ricambio originali!**  
¡Utilizar solamente los **Requetos originales!**  
Only the **original Spare parts** may be used!

**24.501.130**

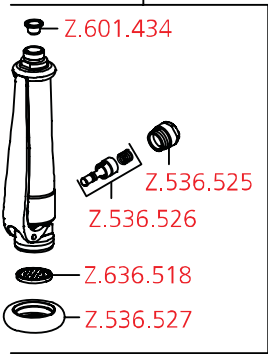
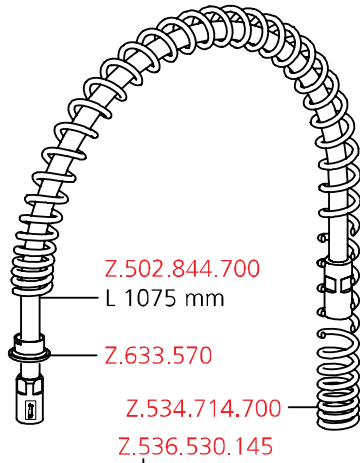

Z.530.360  
ø26 mm  
L= 517 mm

M38 x 1.5

Z.630.339

5/4"

5/4"

ø15

Z.504.182  
ø15 x 3/4"

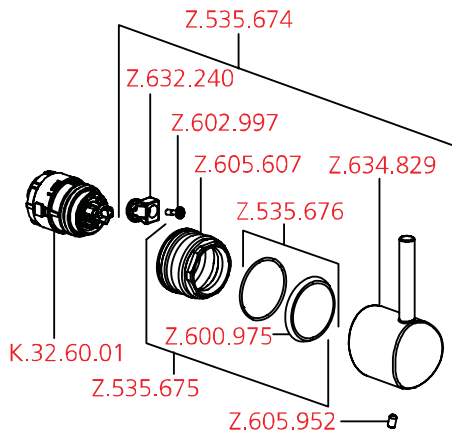

Z.634.116



Z.506.019

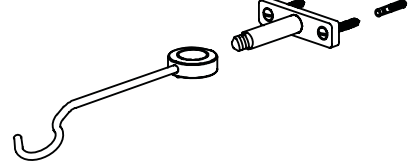

Z.500.897

L = 60 mm, M12

Z.505.221

L = 90 mm, M12

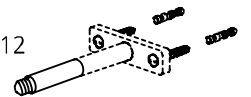

Es dürfen ausschliesslich **original Ersatzteile** verwendet werden!  
 Utiliser seulement des **pièces de rechange originaux!**  
 Usare soltanto i **pezzi di ricambio originali!**  
 ¡Utilizar solamente los **Requetos originales!**  
 Only the **original Spare parts** may be used!

Ersatzteile  
 Pièces de rechange  
 Pezzi di ricambio  
 Repuestos  
 Spare parts

24.501.144 A 200  
 24.501.146 A 300

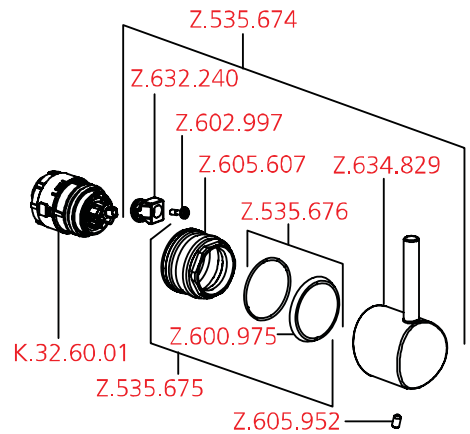
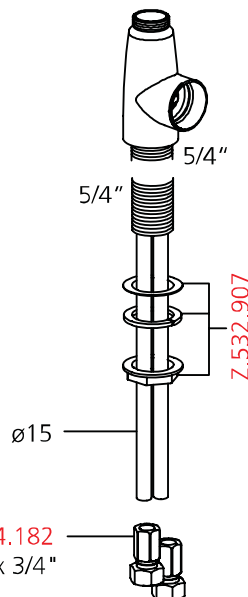
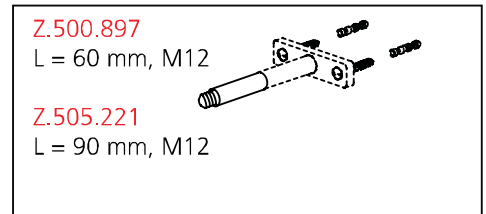
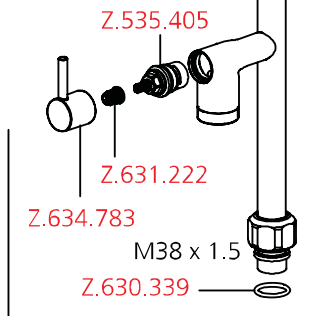
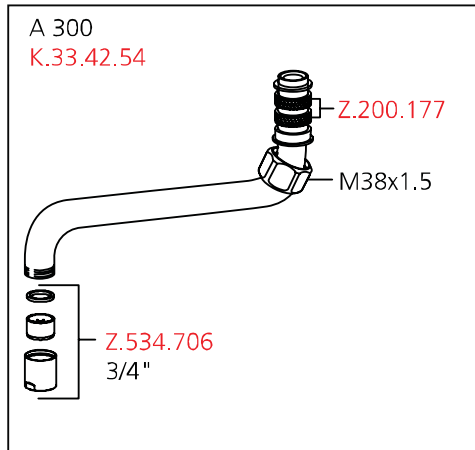
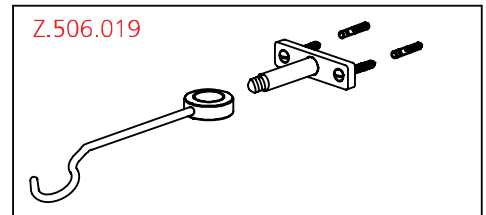
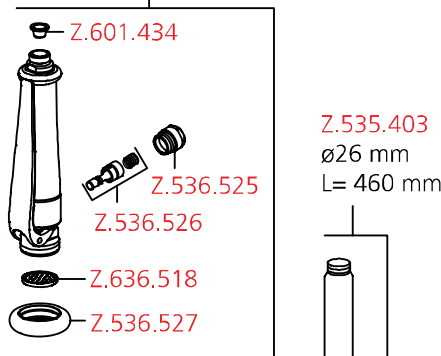
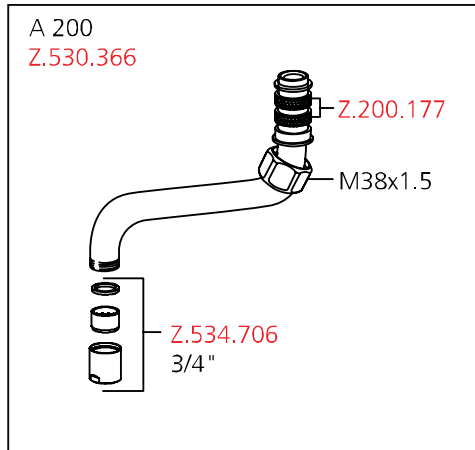
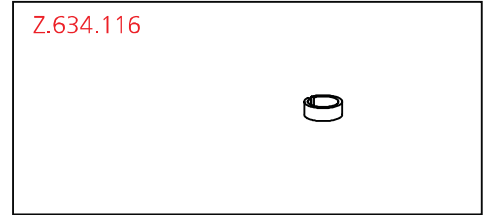
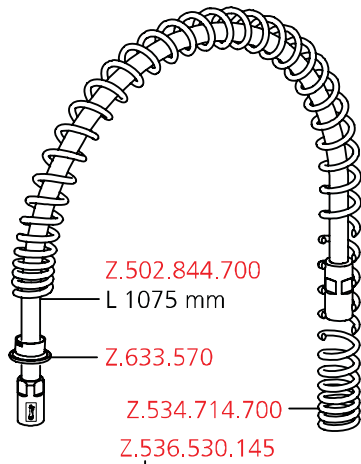



Ersatzteile  
Pièces de rechange  
Pezzi di ricambio  
Repuestos  
Spare parts

Es dürfen ausschliesslich **original Ersatzteile** verwendet werden!  
Utiliser seulement des **pièces de rechange originaux**!  
Usare soltanto i **pezzi di ricambio originali**!  
¡Utilizar solamente los **Requetos originales**!  
Only the **original Spare parts** may be used!

**24.502.164 A 200**  
**24.502.166 A 300**

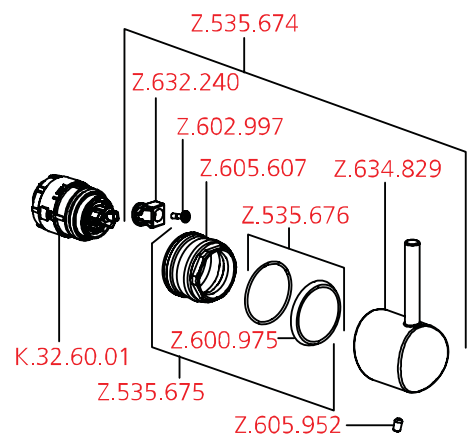
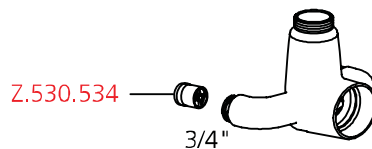
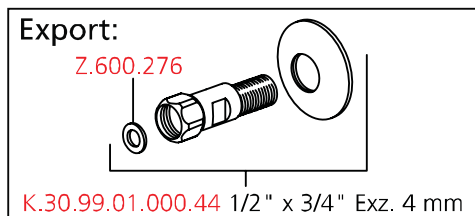
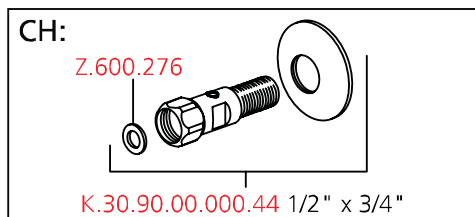
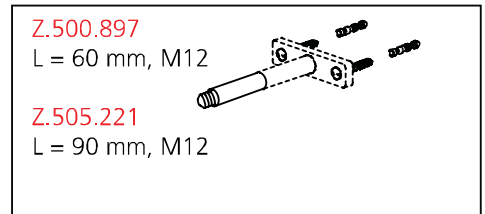
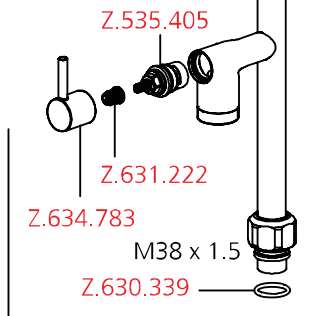
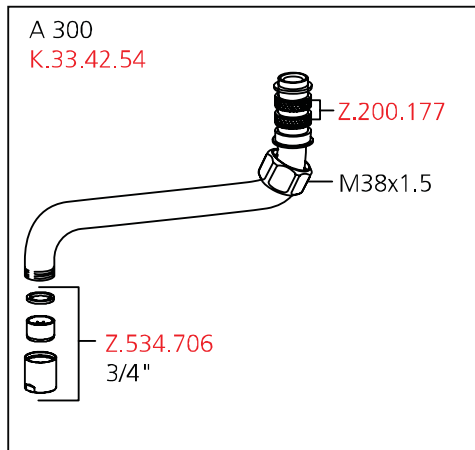
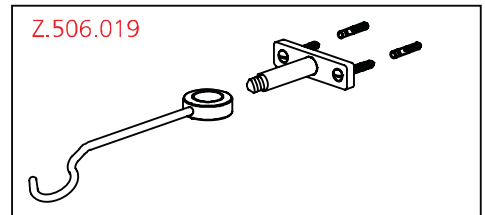
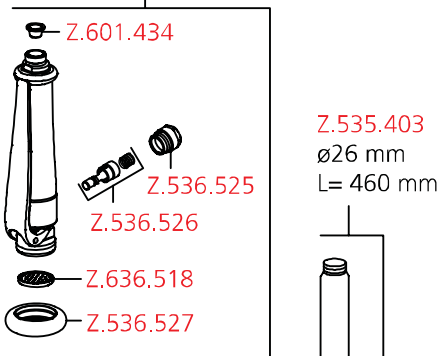
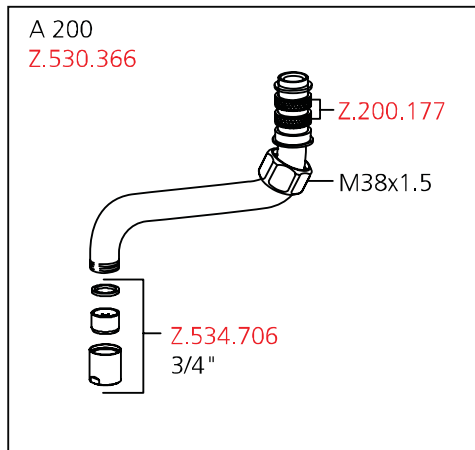
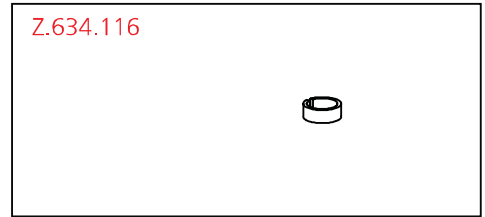
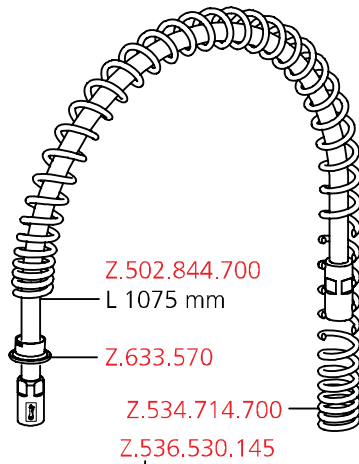

Es dürfen ausschliesslich **original Ersatzteile** verwendet werden!  
 Utiliser seulement des **pièces de rechange originaux!**  
 Usare soltanto i **pezzi di ricambio originali!**  
 ¡Utilizar solamente los **Requetos originales!**  
 Only the **original Spare parts** may be used!

Ersatzteile  
 Pièces de rechange  
 Pezzi di ricambio  
 Repuestos  
 Spare parts

**24.502.194 A 300**  
**24.502.196 A 400**

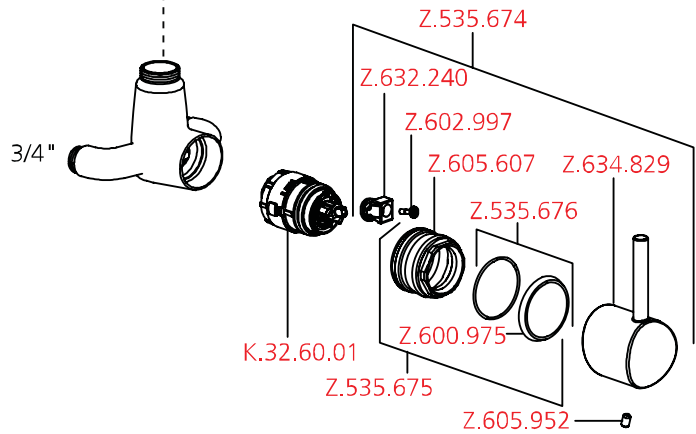
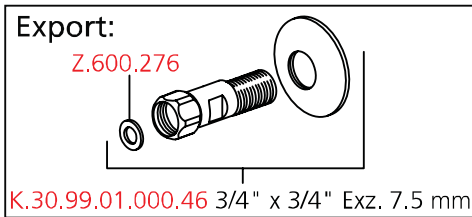
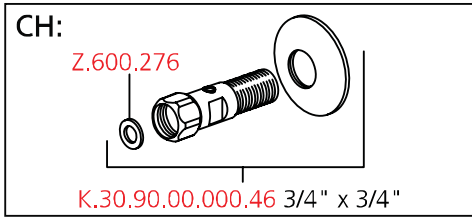
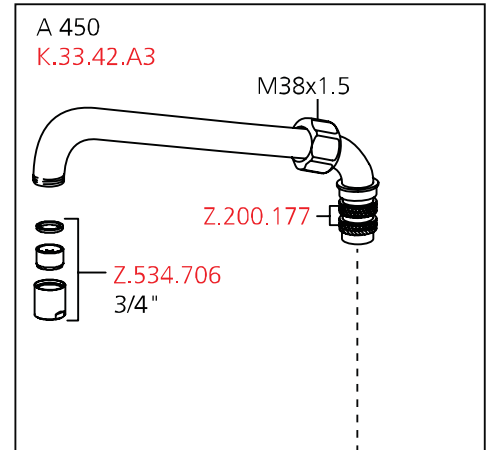
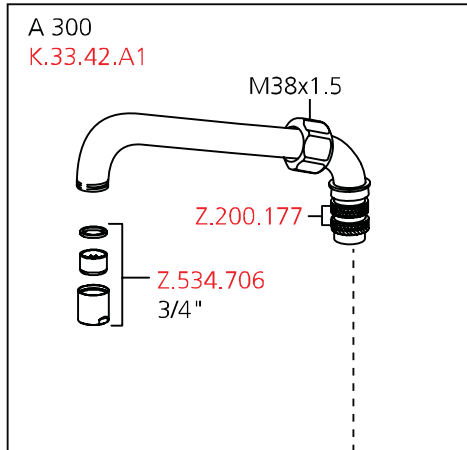

**K.24.32.11.000A60 A 300 CH**  
**K.24.32.14.000A60 A 450 CH**  
**K.24.32.14.000A86 A 300 EXPORT**  
**K.24.32.16.000A86 A 450 EXPORT**

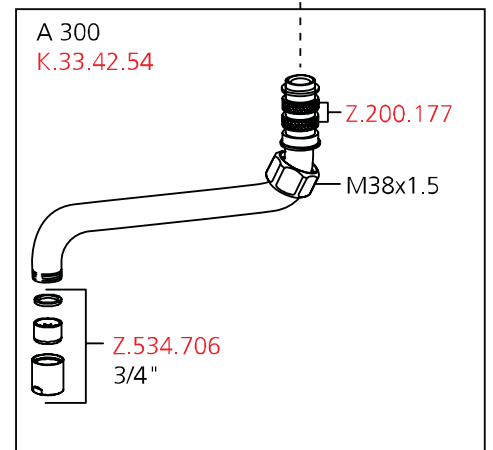
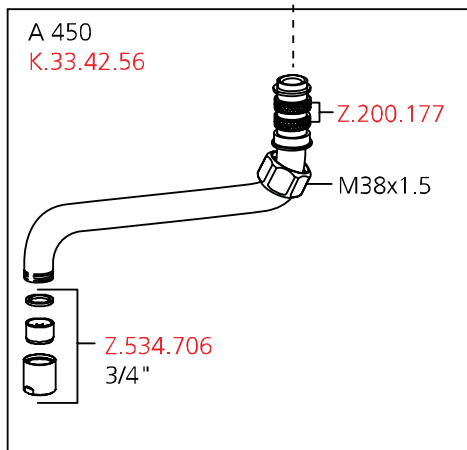
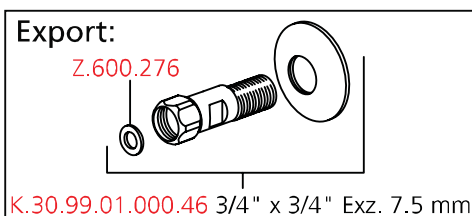
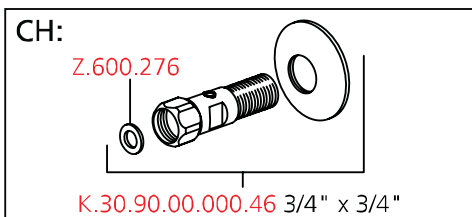
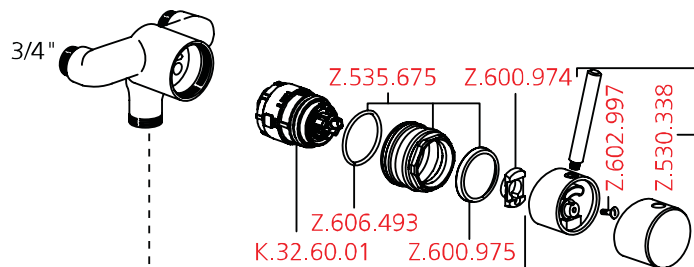

Ersatzteile  
Pièces de rechange  
Pezzi di ricambio  
Repuestos  
Spare parts

Es dürfen ausschliesslich **original Ersatzteile** verwendet werden!  
Utiliser seulement des **pièces de rechange originaux!**  
Usare soltanto i **pezzi di ricambio originali!**  
¡Utilizar solamente los **Requetos originales!**  
Only the **original Spare parts** may be used!

24.503.114 A 200  
24.503.116 A 300

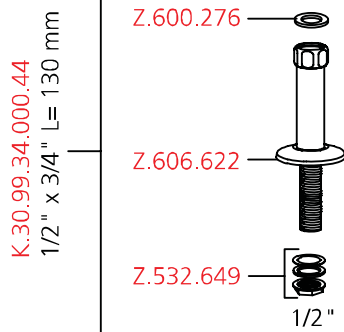
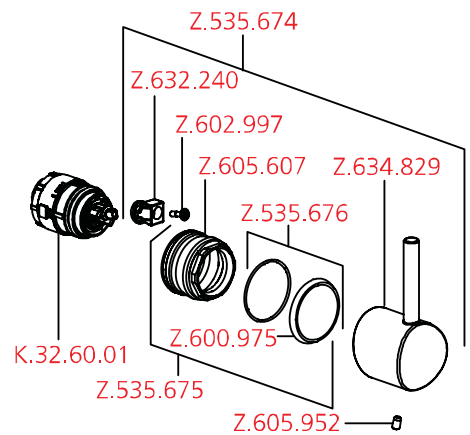
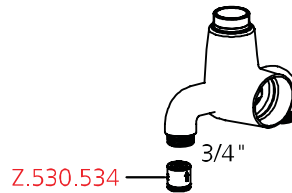
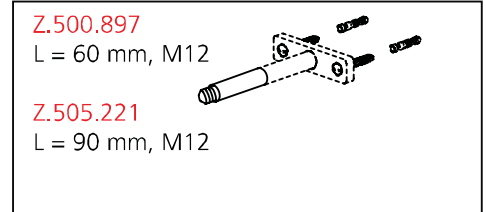
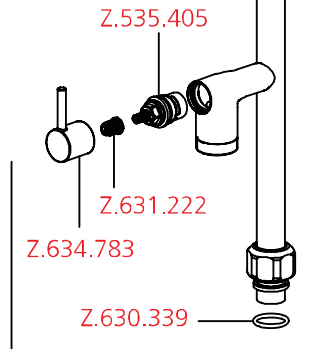
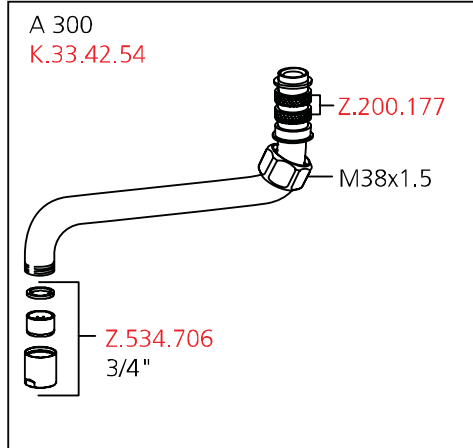
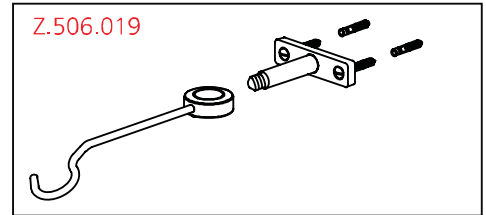
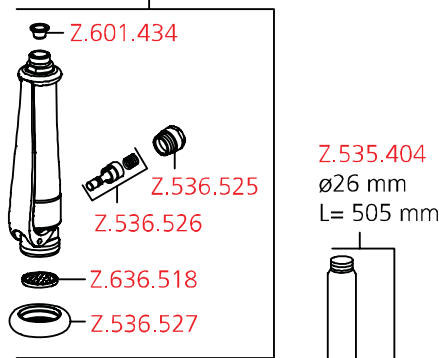
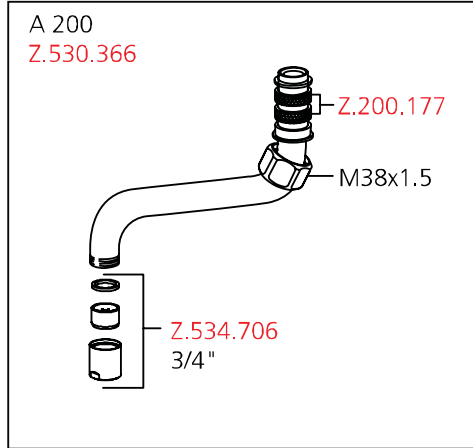
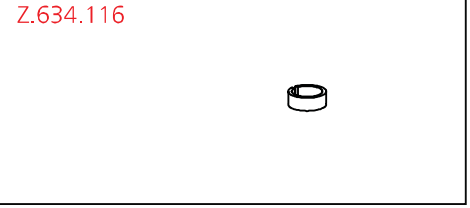
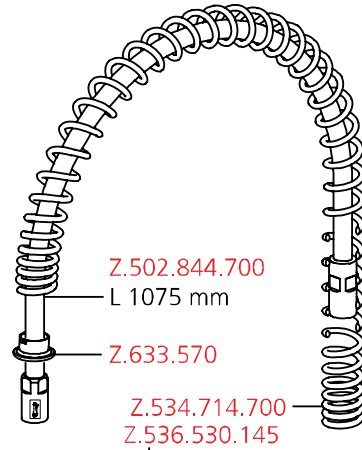

Es dürfen ausschliesslich **original Ersatzteile** verwendet werden!  
 Utiliser seulement des **pièces de rechange originaux!**  
 Usare soltanto i **pezzi di ricambio originali!**  
 ¡Utilizar solamente los **Requetos originales!**  
 Only the **original Spare parts** may be used!

Ersatzteile  
 Pièces de rechange  
 Pezzi di ricambio  
 Repuestos  
 Spare parts

### 24.503.124 A 200

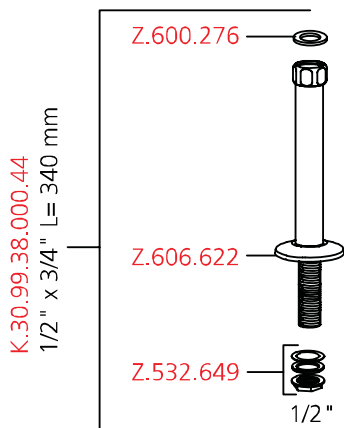
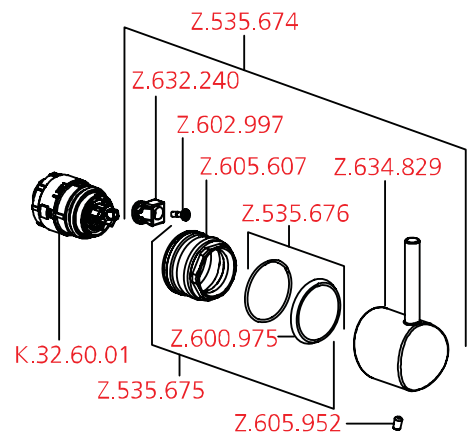
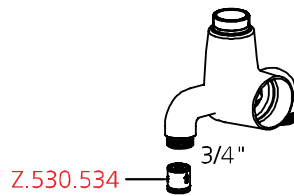
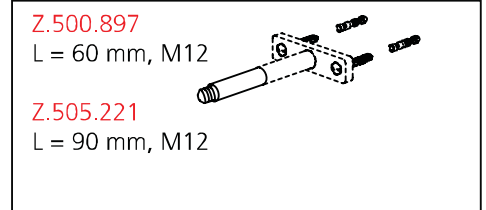
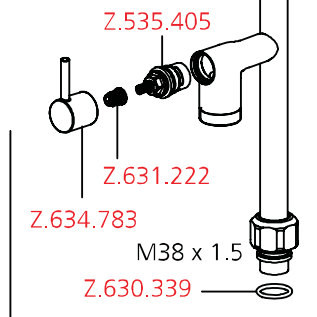
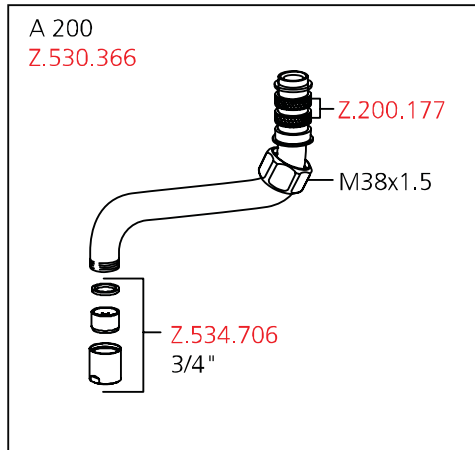
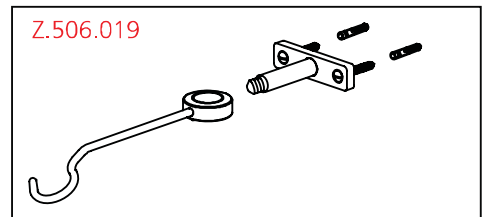
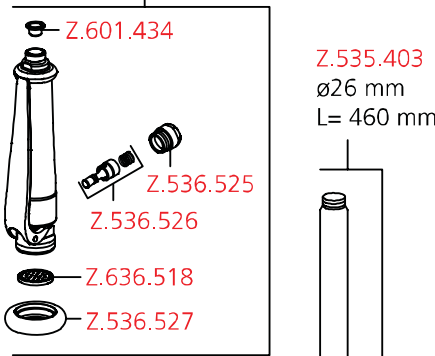
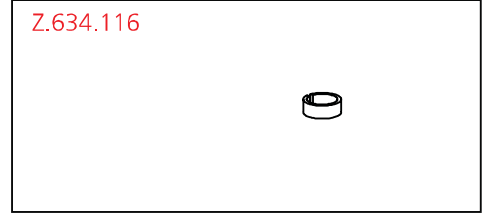
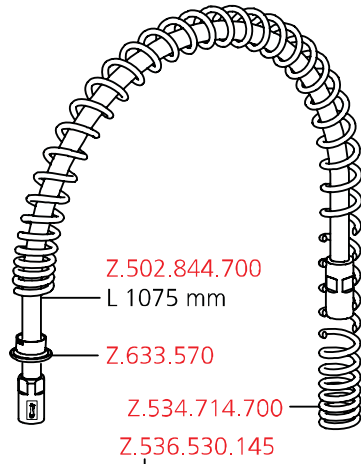

K.30.99.38.000.44  
 1/2" x 3/4" L= 340 mm

Ersatzteile  
Pièces de rechange  
Pezzi di ricambio  
Repuestos  
Spare parts

Es dürfen ausschliesslich **original Ersatzteile** verwendet werden!  
Utiliser seulement des **pièces de rechange originaux!**  
Usare soltanto i **pezzi di ricambio originali!**  
¡Utilizar solamente los **Requetos originales!**  
Only the **original Spare parts** may be used!

**24.503.126 A 300**

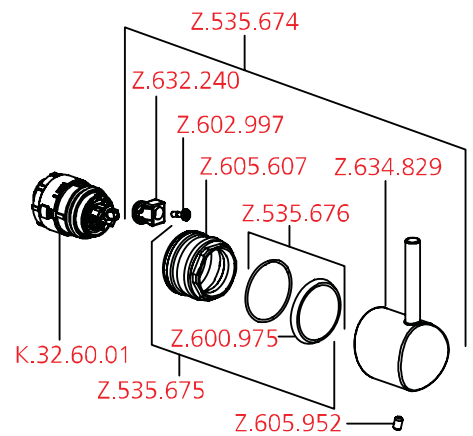
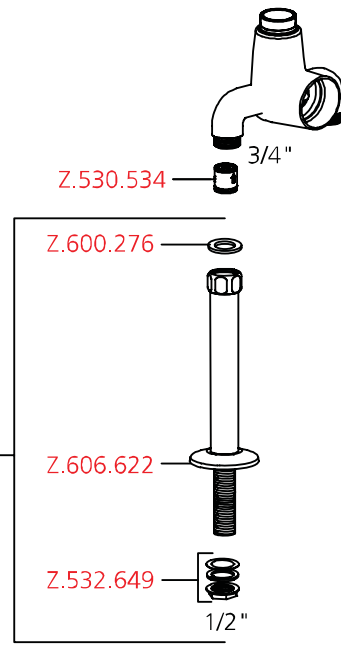
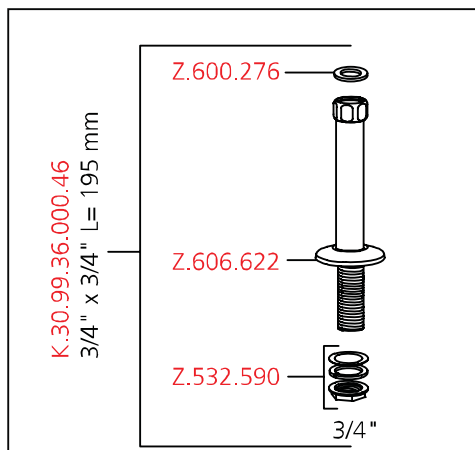
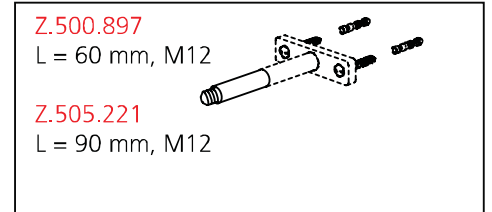
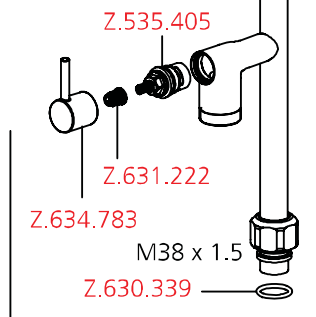
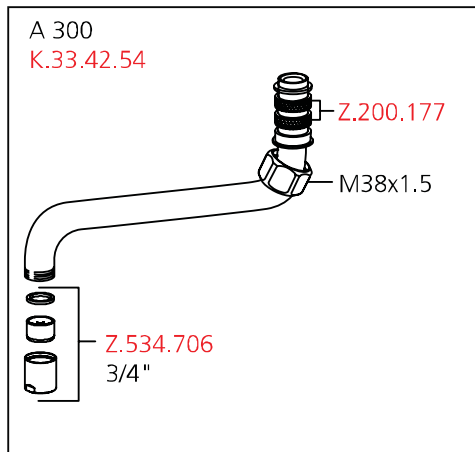
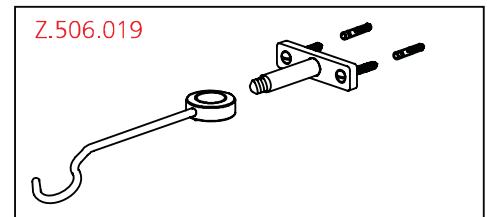
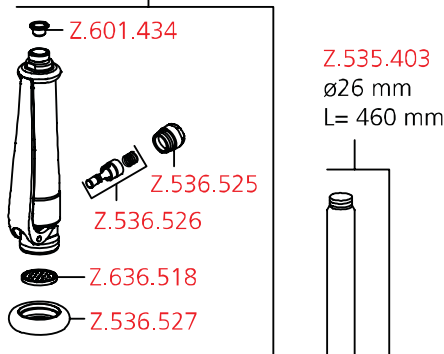
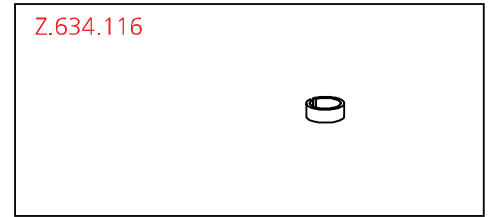
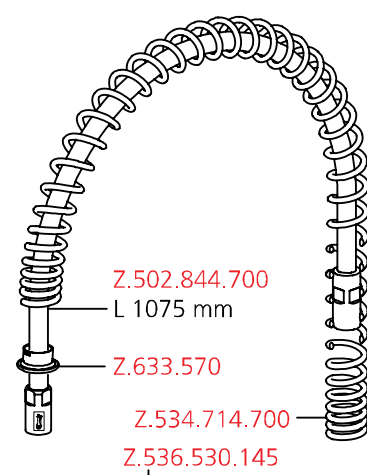
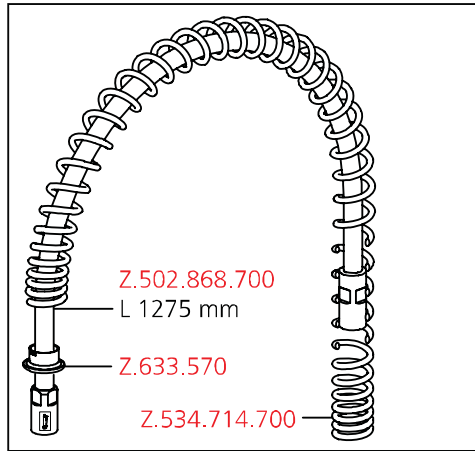

Es dürfen ausschliesslich **original Ersatzteile** verwendet werden!  
 Utiliser seulement des **pièces de rechange originaux!**  
 Usare soltanto i **pezzi di ricambio originali!**  
 ¡Utilizar solamente los **Requetos originales!**  
 Only the **original Spare parts** may be used!

Ersatzteile  
 Pièces de rechange  
 Pezzi di ricambio  
 Repuestos  
 Spare parts

A 300  
 K.33.42.A1

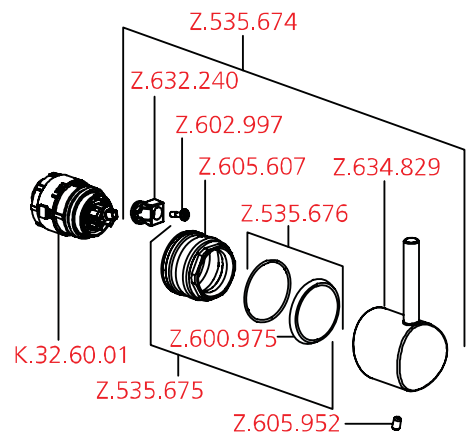
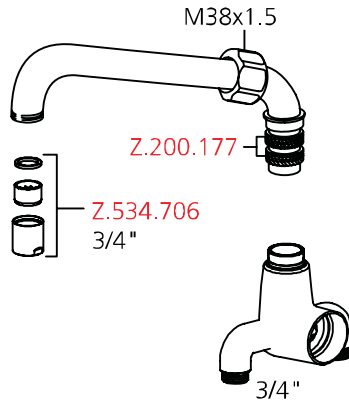

**24.503.174 A 300**

**24.503.184 A 300**

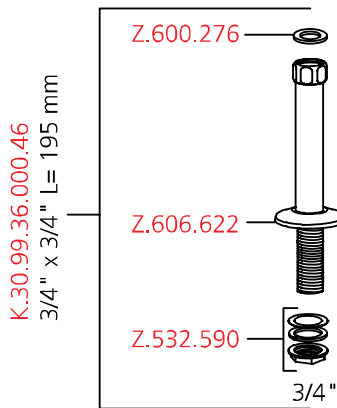
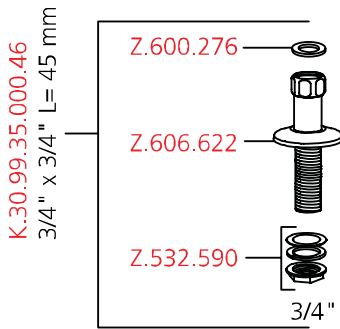

## Pflegeanleitung für Armaturen und Zubehör

### Instruction pour la maintenance des robinets et des accessoires

### Istruzioni per la manutenzione di rubinetti e accessori

### Instrucciones para el cuidado de griferias y accesorios

### Maintenance / Cleaning instructions for faucets and accessories

#### Grundsätzliche Reinigungshinweise:

- Beim Reinigen muss die Oberfläche der Armatur kalt sein (Wärme beschleunigt die Zerstörung der Oberfläche)!
- Reinigungshinweise der Reinigungsmittelhersteller beachten!

#### Die Pflege:

- Armatur täglich mit weichem Lappen trocken reiben!
- Scheuernde Reinigungsmittel und Putzschwämme unbedingt vermeiden!

#### Die Reinigung:

- Schmutz- oder Kalkflecken auf der Armaturenoberfläche nur mit mildem Reinigungsmittel entfernen!
- Sofort nach dem Reinigen alle Reinigungsmittelrückstände mit kaltem Wasser wegspülen!
- Mit weichem Lappen trocken reiben.

#### Instructions principales pour le nettoyage:

- Durant le nettoyage, la surface du robinet doit être froide (la chaleur accélère l'usure de la surface)!
- Nous vous prions de faire attention aux indications mentionnées sur les nettoyages!
- Assurez vous que les produits ne contiennent pas d'acides ou des substances corrosives.

#### L'entretien:

- Le robinet doit être nettoyé chaque jour avec un chiffon mou.
- Evitez absolument l'usage des brillants pour métaux, éponges abrasives ou produits similaires!

#### Le nettoyage:

- Enlevez salissures et dépôts calcaires de la surface du robinet seulement avec des produits qui ne sont pas agressifs!
- Immédiatement après le nettoyage, rincer bien les résidus des détergents avec de l'eau froid!
- Sécher avec un chiffon mou.

#### Principali istruzioni per la pulizia:

- Durante la pulizia, la superficie del rubinetto deve essere fredda (il calore accelera il logorio della superficie)!
- Fare attenzione alle indicazioni riportate sui prodotti per la pulizia!
- Accertarsi che non contengano acidi o sostanze corrosive.

#### La manutenzione:

- Il rubinetto deve essere asciugato quotidianamente con un panno morbido.
- Evitare assolutamente paglietta, spugne abrasive o similari!

#### La pulizia:

- Togliere sporco e calcare dalla superficie del rubinetto solo con detersivi non aggressivi!
- Subito dopo la pulizia, sciacquare bene i residui di detersivo con acqua fredda!
- Asciugare con un panno morbido.

#### Avisos básicos de limpieza:

- Cuando se procede a limpiar la griferia, su superficie debe estar fría (el calor acelera la destrucción de la superficie)!

- Respetar los avisos de limpieza del fabricante del detergente!

#### Cuidado:

- Secar la griferia frotando diariamente con un paño blando!
- Evite, imprescindiblemente, detergentes y esponjas de limpieza raspantes!

#### Limpieza:

- Quitar las manchas de suciedad o cal en la superficie de la griferia sólo con un detergente poco agresivo!
- Inmediatamente después de la limpieza eliminar, enjuagando con agua fría, todos los residuos del detergente!
- Secar frotando con un paño blando.

#### General Cleaning Instructions:

- Faucet surface must be of room temperature before cleaning (elevated temperature increases damage of the surface).
- Cleaning instructions of the detergent manufacturer must be followed.

#### Maintenance:

- Rub the faucet daily dry with a soft cloth.
- Never use corrosive cleaners or cleaning pads.

#### Cleaning:

- Dirt or calcium deposits on the faucet surface must be removed with soft detergent or with soap water!
- Rinse well with water immediately after cleaning, until all detergent ie removed from the surface.
- Dry with soft cloth.



Recyclingpapier auf 100% Altpapierbasis.  
 Papier de recyclage sur 100% bases de vieux papier.  
 Riciclaggio della carta sulla base della carta straccia di 100%.  
 Reciclaje del documento sobre base del papel usado del 100%.  
 Recycling paper on 100% waste paper basis.



- D Schäden, die infolge unsachgemässer Behandlung, natürlicher Abnutzung oder zu grosser Inanspruchnahme entstanden sind, sind von unseren Garantieleistungen ausgeschlossen!
- F Ces dommages survenus en raison d'un traitement inadéquat, des signes d'usure traitement inadéquat, naturels ou du grand utilisation, sont exclus de notre garantie.
- I Danni ai rubinetti, conseguenti da un trattamento non appropriato, sono esclusi dalla nostra garanzia!
- Sp Daños, debidos a un tratamiento inadecuado, son excluidos de la nuestra garantía.
- E Damages on the faucet resulting from incorrect handling are excluded from the manufacturers warranty!

