

6

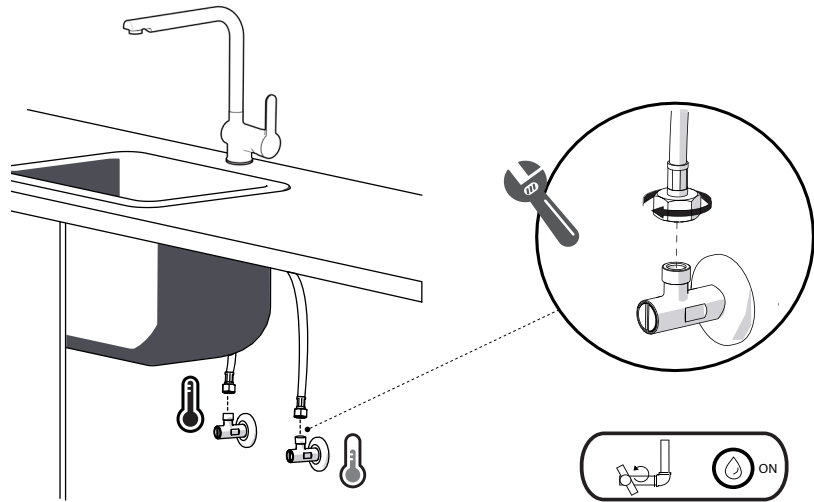

Montageanleitung // Assembly instructions

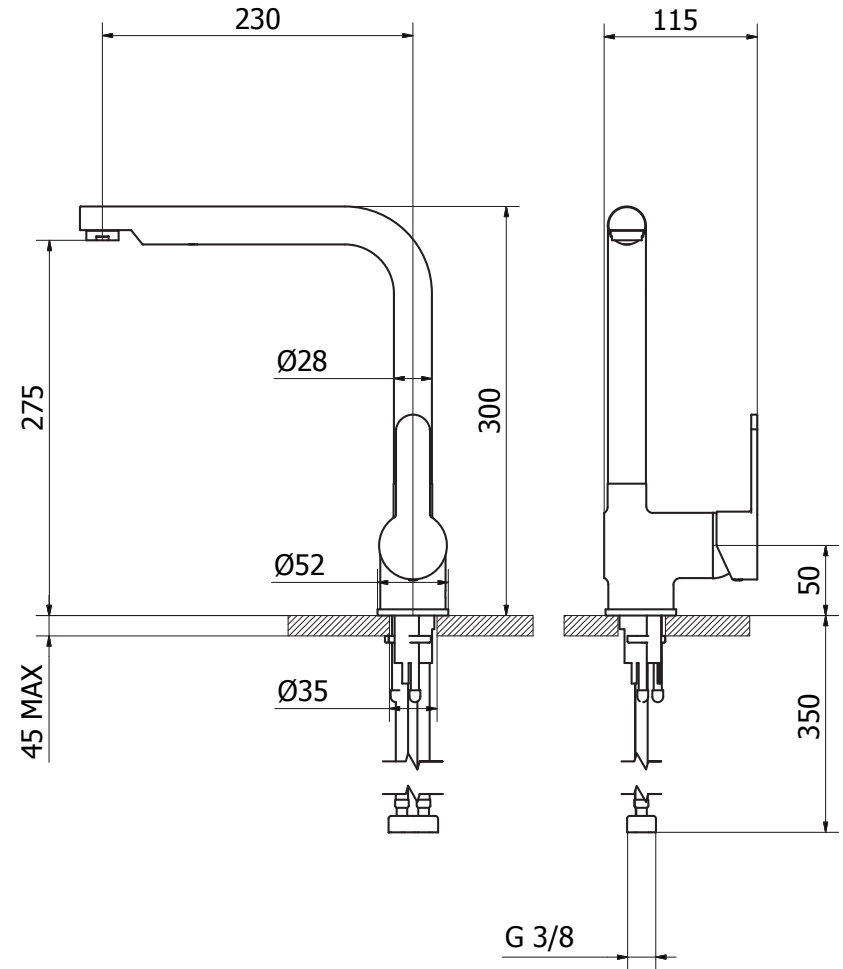

REINIGUNG CLEANING

 MIN Druck min. Minimum pressure 0,5 BAR	MAX Druck max. Max pressure 5 BAR
Temperatur max 85 °C Max temperature	

 WASSER WATER <input checked="" type="checkbox"/>	 ALKOHOL ALCOL <input checked="" type="checkbox"/>	 WASCHMITTEL DETERGENT <input checked="" type="checkbox"/>
 MIKROFASERN MICROFIBER <input checked="" type="checkbox"/>	 SCHWAMM SPONGE <input checked="" type="checkbox"/>	<input checked="" type="checkbox"/>

