



Wasser erleben

HANSAPOLO

INSTALLATION AND MAINTENANCE GUIDE



Contents

CZ Obsah	FI Sisällysluettelo	IT Indice	PT Conteúdo
DE Inhaltsübersicht	FR Sommaire	NL Inhoud	RU Содержание
DK Indholdsfortegnelse	GR Περιεχόμενα	NO Innhold	SE Innehållsförteckning
ES Contenidos	HU Tartalom	PL Spis treści	SK Obsah



Technical data	4-5
Installation	8
Operation.....	11
Maintenance.....	11-15, 17
Spare parts.....	18

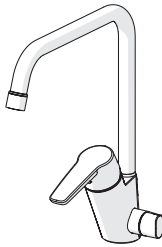

Technical data	5-6
Installation	8,10
Operation.....	11
Maintenance.....	11-13, 17
Spare parts.....	20

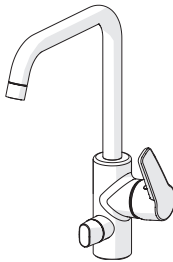

Technical data	6-7
Installation	9
Operation.....	11
Maintenance.....	11-13, 16-17
Spare parts.....	19

5148 2293

EN 817
 50 - 1000 kPa
 0.2 l/s (300 kPa)
 max. +80°C

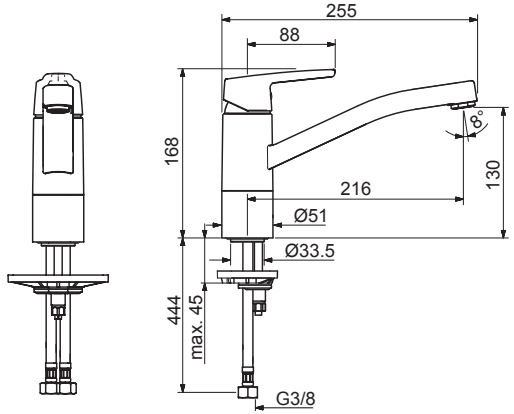

5266 2293

EN 817
 50 - 1000 kPa
 0.2 l/s (300 kPa)
 max. +80°C

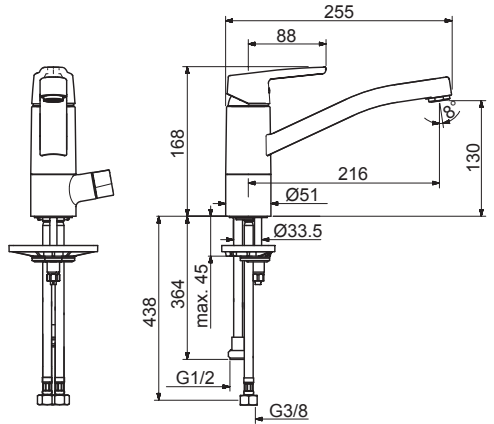

5159 1193

EN 817
 50 - 500 kPa
 0.12 l/s (300 kPa)
 max. +80°C

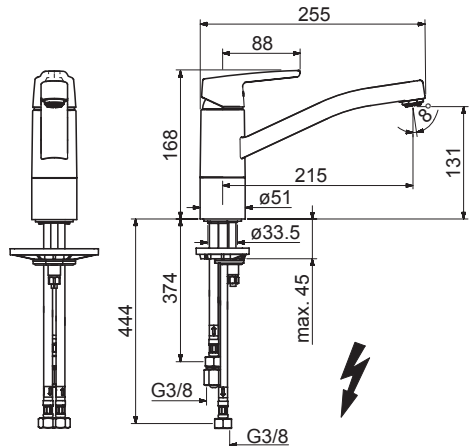

5156 2293

EN 817
 50 -1000 kPa
 0.2 l/s (300 kPa)
 max. +80°C

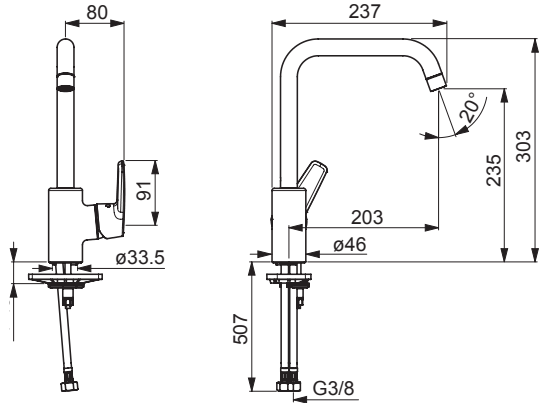

5160 2293

EN 817
 50 -1000 kPa
 0.2 l/s (300 kPa)
 max. +80°C

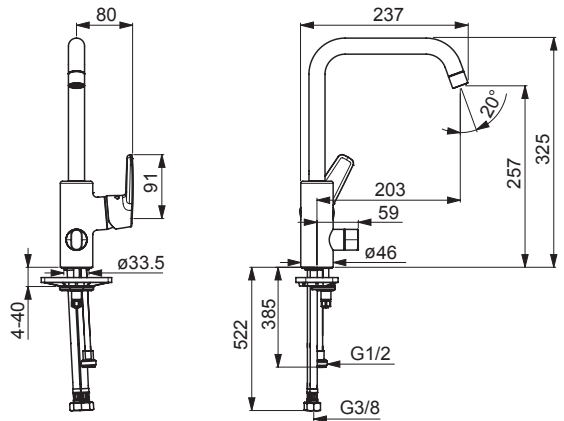

5270 2293

EN 817
 50 -1000 kPa
 0.2 l/s (300 kPa)
 max. +80°C

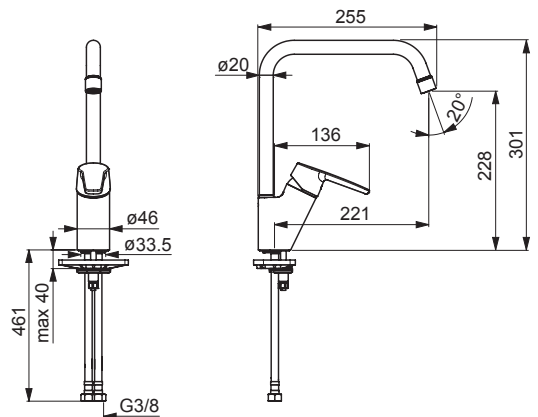

5156 2293 0037

EN 817
 50 -1000 kPa
 0.12 l/s (300 kPa)
 max. +80°C

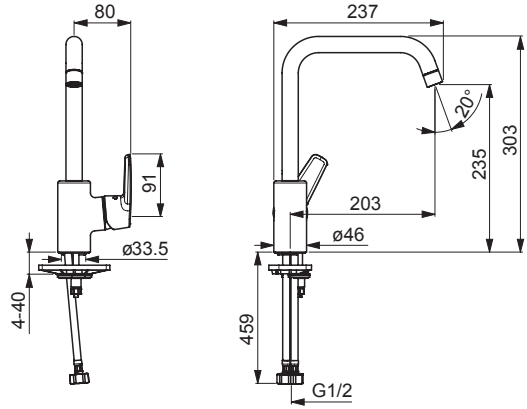

5148 2293 0037

EN 817
 50 -1000 kPa
 0.12 l/s (300 kPa)
 max. +80°C

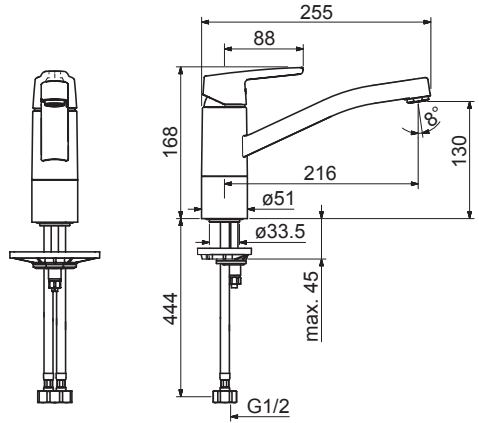

5148 2293 00676

EN 817
 50 -1000 kPa
 0.2 l/s (300 kPa)
 max. +80°C

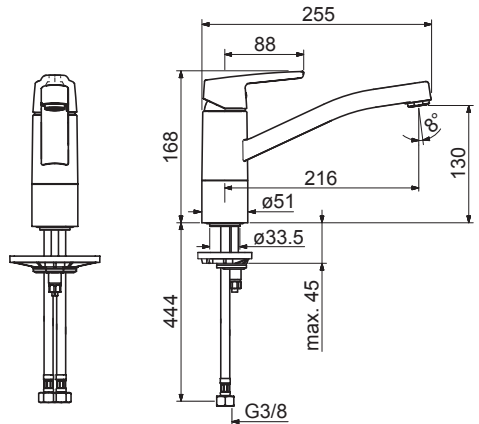

Installation

CZ Montáž

DE Montage

DK Installation

ES Montaje

FI Asennus

FR Installation

GR Συναρμολόγηση

HU Szerelés

IT Montaggio

NL Installatie

NO Montering

PL Instalacja

PT Instruções

RU Установка

SE Installation

SK Inštalácia

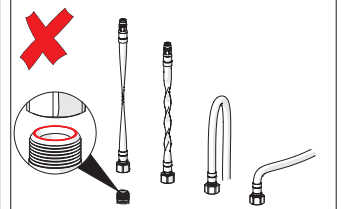
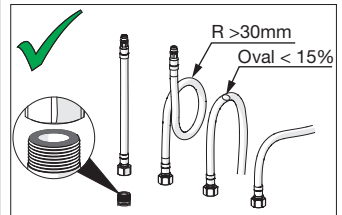
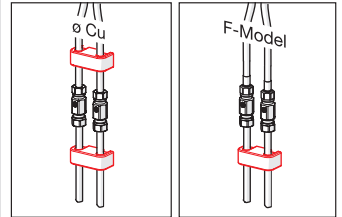
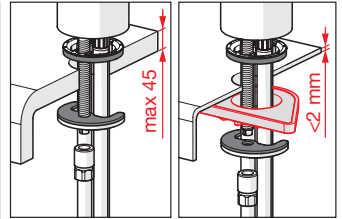
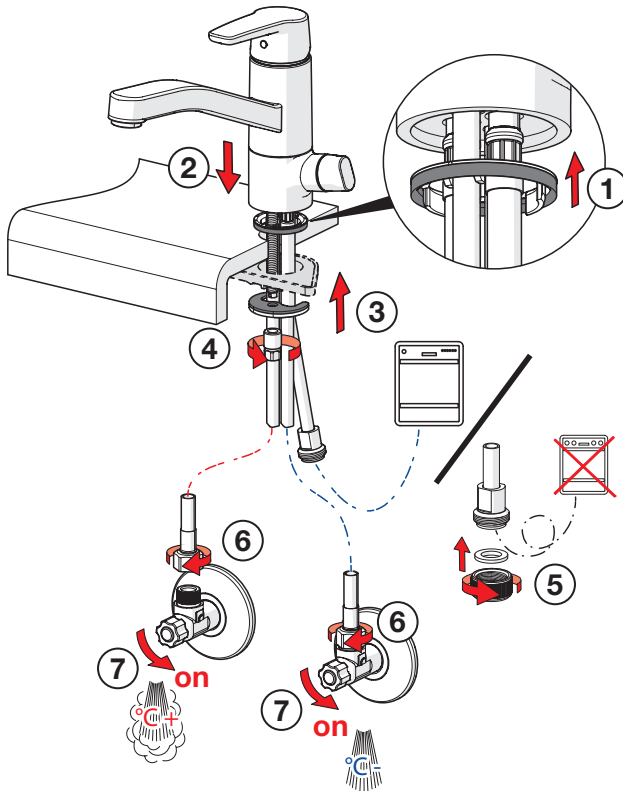
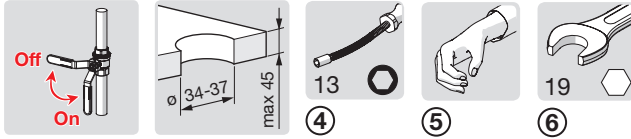

Installation

CZ Montáž

DE Montage

DK Installation

ES Montaje

FI Asennus

FR Installation

GR Συναρμολόγηση

HU Szerelés

IT Montaggio

NL Installatie

NO Montering

PL Instalacja

PT Instruções

RU Установка

SE Installation

SK Inštalácia

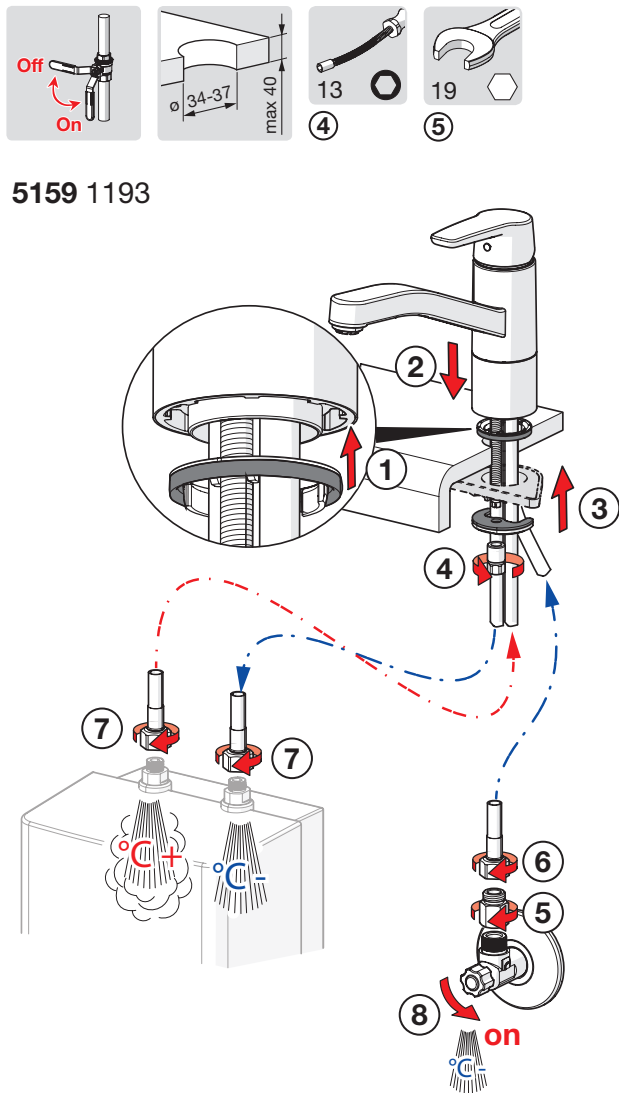

5159 1193

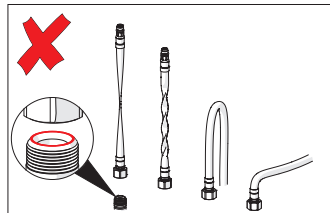
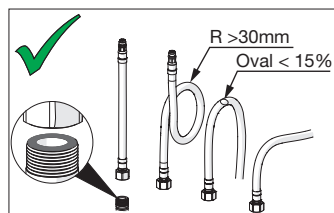
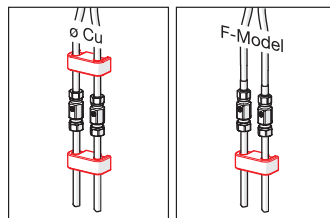
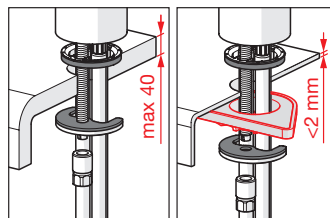

Spout installation

CZ Instalace výtokového ramene **GR** Εγκατάσταση χείλους εκροής
DE Montage Auslauf **HU** A kifolyó felszerelése
DK Montering af tud **IT** Montaggio bocca
ES Instalación del caño **NL** Installatie uitloop
FI Juoksuputken asennus **NO** Montering av tut
FR Montage du bec

PL Instalacja wylewki **PT** Instalação do bico
RU Установка излива **SE** Montering av utloppspip
SK Inštalácia výtokového ramena

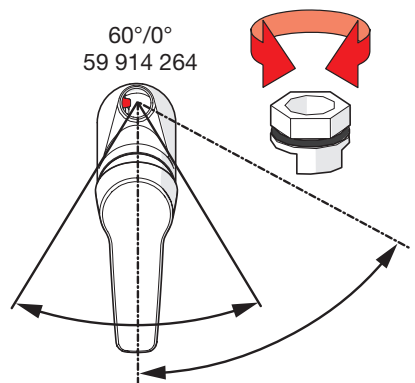
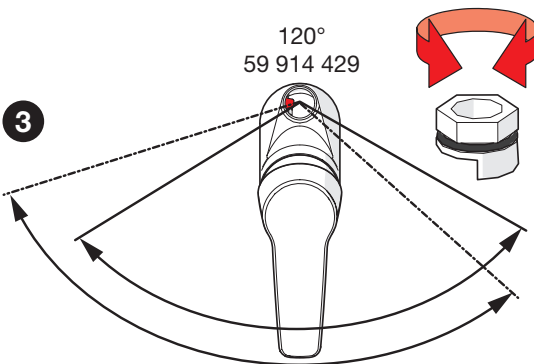
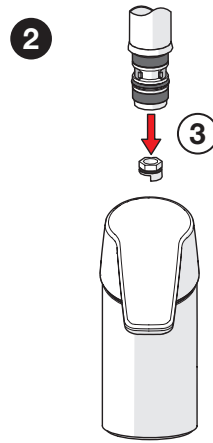
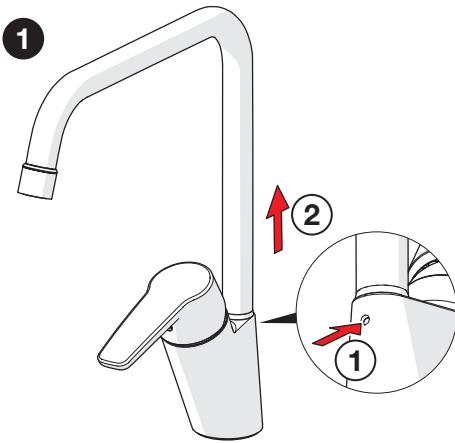

Operation

CZ Funkce
DE Funktion
DK Betjening
ES Servicio

FI Toiminta
FR Utilisation
GR Λειτουργία
HU Üzemeltetés

IT Funzionamento
NL Bediening
NO Funksjon
PL Działanie

PT Funcionamento
RU Принцип действия
SE Funktion
SK Prevádzka

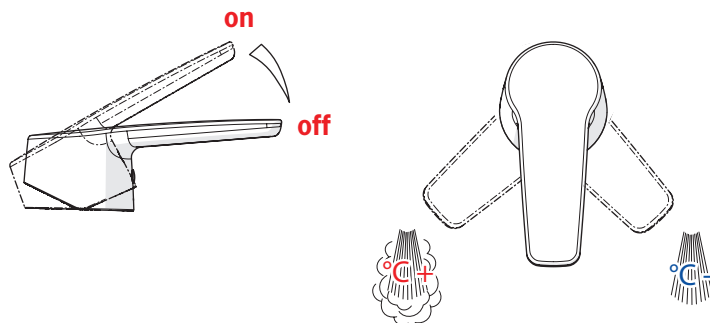

Limiting the flow rate

CZ Omezení průtoku
DE Bergenzung der Durchflußmenge
DK Begrænsning af vandmængden
ES Limitación de la tasa de flujo
FI Virtaaman rajoitus
FR Limitation du débit
GR Περιορισμός ρυθμού ροής
HU Az áramlás határolása

IT Limitazione della portata
NL Begrenzing van de doorstroomhoeveelheid
NO Begrensning av vannmengde
PL Ograniczenie wielkości strumienia
PT Limitar o caudal
RU Регулирование потока
SE Flödesbegränsning
SK Obmedzenie prietoku

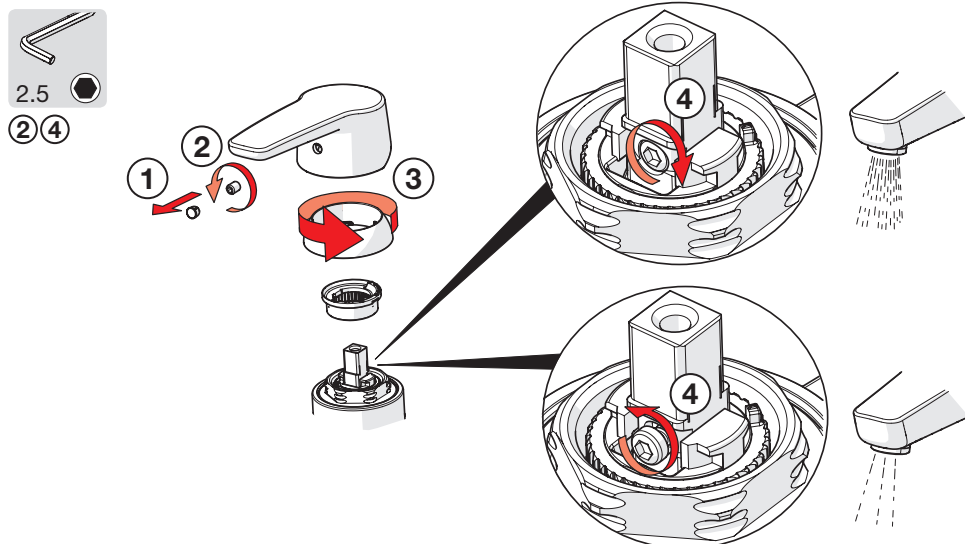

Limiting temperature

CZ Omezení teplé vody	NL Perlator vervangent
DE Temperaturbegrenzung	NO Begrenzing temperatuur
DK Forindstilling af vandets max. temperatur	PL Ograniczenie temperatury
ES Limitación de la temperatura	PT Limitar a temperatura
FI Lämpötilan rajoitus	RU Ограничение температуры в регулирующем блоке
FR Limitation de la température	SE Begränsning av vattnets max. temperatur
GR Περιορισμός θερμοκρασίας	SK Obmedzenie teploty
HU A hőmérséklet határolása	
IT Limitazione della temperatura	

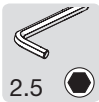

2.5

②

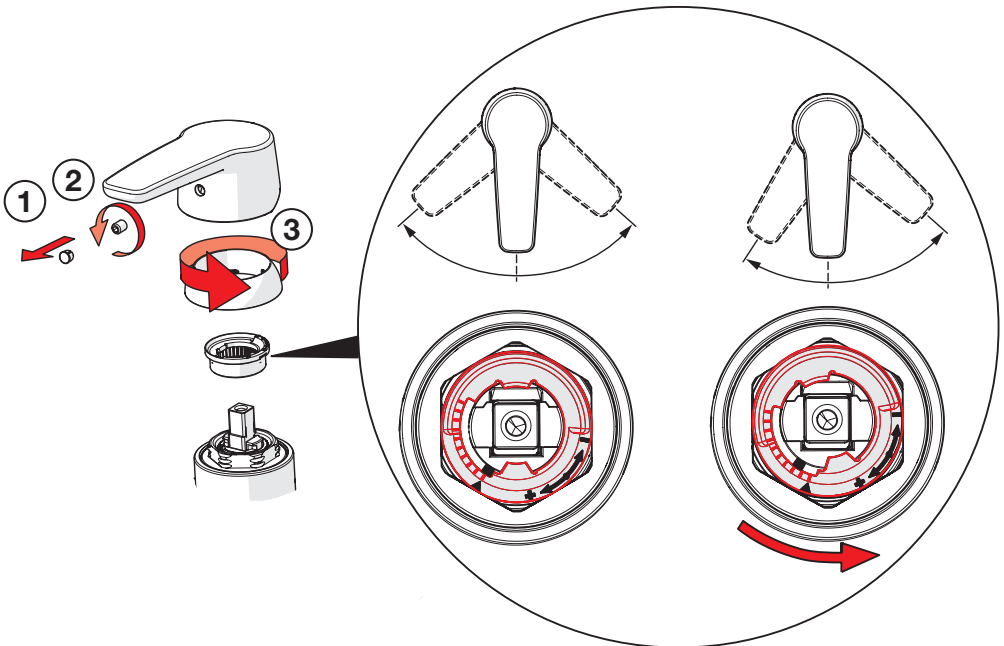

To change the cartridge

CZ Výměna kartuše

DE Auswechseln der Patrone

DK Udskiftning af reguleringskassette (unit)

ES Montaje del cartucho

FI Säätöosan vaihto

FR Montage et démontage de la cartouche

GR Αντικατάσταση του στοιχείου

HU A patron cseréje

IT Montaggio della cartuccia

NL Vervangen van het keramische binnenwerk

NO Skifting av kassett

PL Wymiana modułu sterującego

PT Substituição do cartucho

RU Замена регулировочного блока

SE Byte av kassett

SK Výměna kartuše

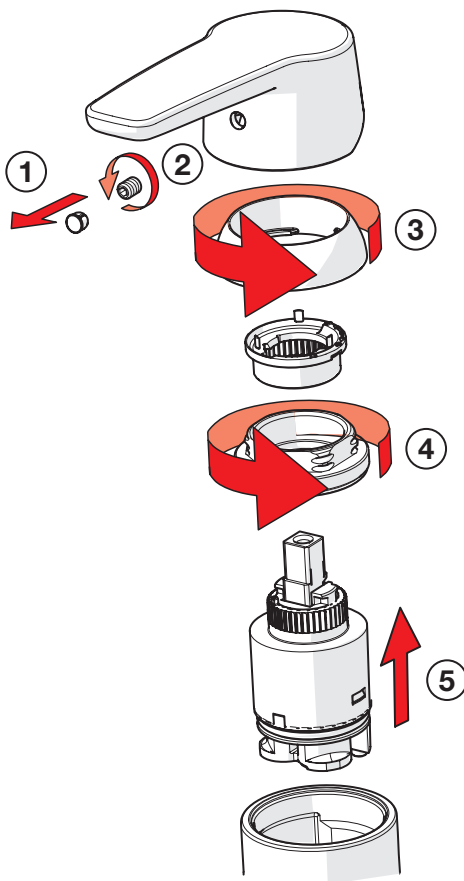
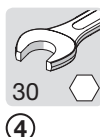
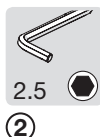
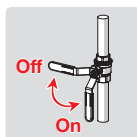

Changing the spout's seals

CZ Výměna těsnění

DE Austausch der Auslaufdichtungen

DK Udskiftning af svingtudens pakninger

ES Cambio de las juntas del caño

FI Juoksuputken tiivisteiden vaihto

FR Remplacement des joints de bec

GR Αλλαγή στεγανοποιητικών χείλους εκροής

HU A kifolyó tömitésének cseréje

IT Sostituzione delle guarnizioni delle bocca

NL Lippendichtingen vervangen

NO Bytting av svingtudens pakninger

PL Wymiana uszczelzek wylewki

PT Substituir a vedação do bico

RU Замена прокладок сливной трубы или замена сливной трубы

SE Utbyte av manschettpackingar

SK Výměna tesnení

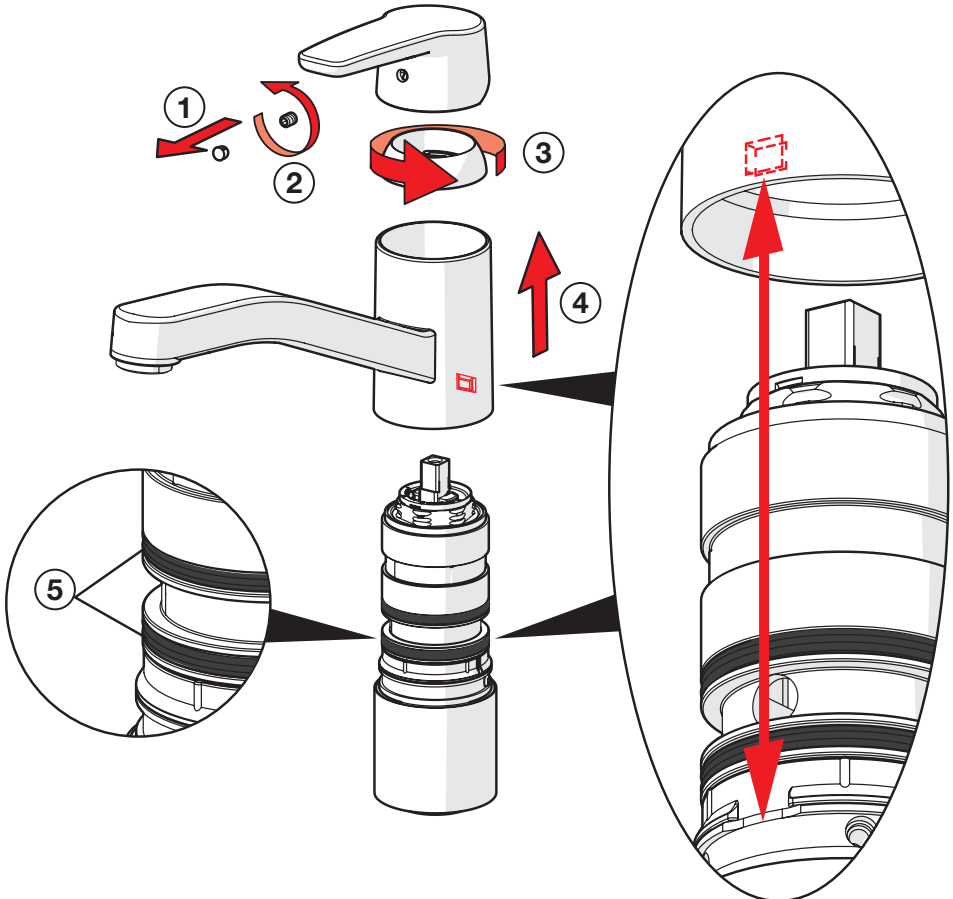
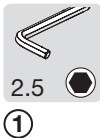
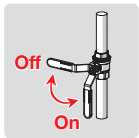

To change the spout's swing angle

CZ Výміна výtokového ramene

DE Den Schwenkbereich des Auslaufs ändern

DK Ændring af tudens svingradius

ES Variación del radio d'azione della bocca

FI Juoksutputken kääntymiskulman muuttaminen

FR Changement de la rotation du bec

GR Για αλλαγή της γωνίας στροφής του χείλους εκροής

HU A kifolyó hajlásszögének módosítása

IT Per modificare l'angolo di rotazione della bocca

NL Om de draaihoek van de uitloop te wijzigen

NO Begrensning av tudens svingutslag

PL W celu zmiany kąta obrotu wylewki

PT Para mudar o ângulo de rotação do bico

RU Изменение угла поворота излива

SE Ändring av utloppsrörens svängradie

SK Možnosť zmeny veľikosti úhlu otáčení výtokového ramene

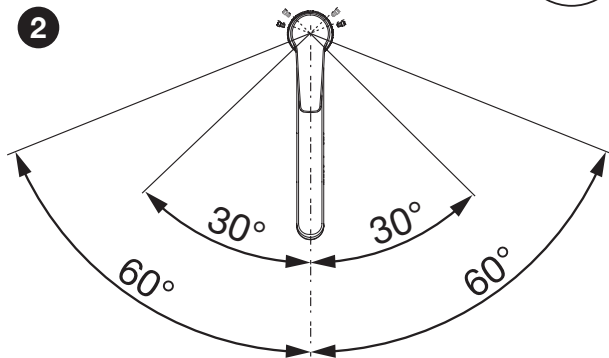
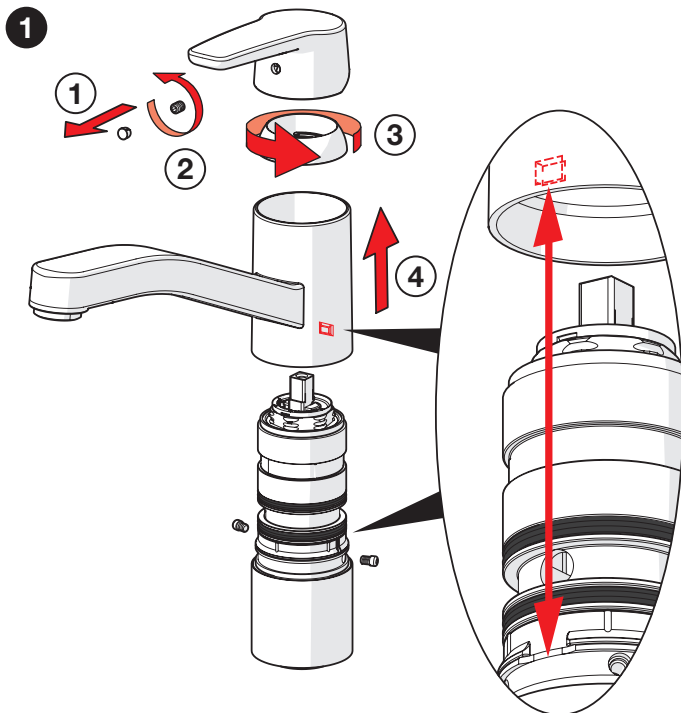
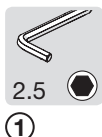
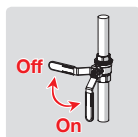

To change the spout's swing angle

CZ Výміна výtokového ramene

DE Den Schwenkbereich des Auslaufs ändern

DK Ændring af tudens svingradius

ES Variación del radio d'azione della bocca

FI Juoksuputken kääntymiskulman muuttaminen

FR Changement de la rotation du bec

GR Για αλλαγή της γωνίας στροφής του χείλους εκροής

HU A kifolyó hajlásszögének módosítása

IT Per modificare l'angolo di rotazione della bocca

NL Om de draaihoek van de uitloop te wijzigen

NO Begrensning av tudens svingutslag

PL W celu zmiany kąta obrotu wylewki

PT Para mudar o ângulo de rotação do bico

RU Изменение угла поворота излива

SE Ändring av utloppspipens svängradie

SK Možnosť zmeny veľikosti úhlu otáčeni výtokového ramene

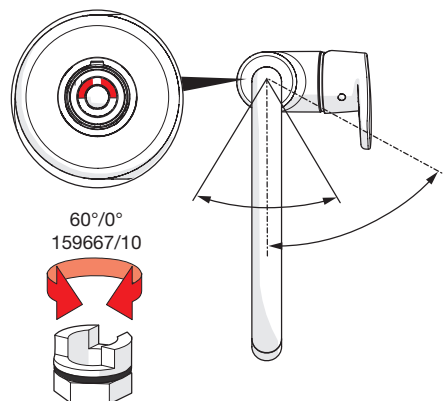
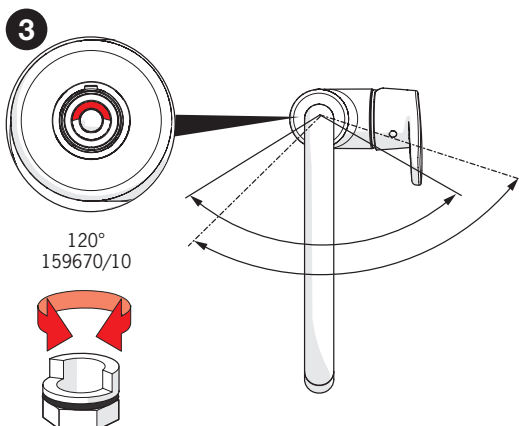
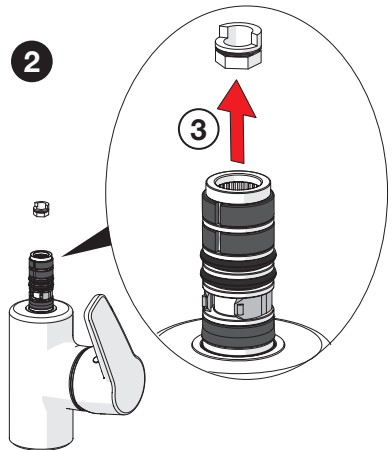
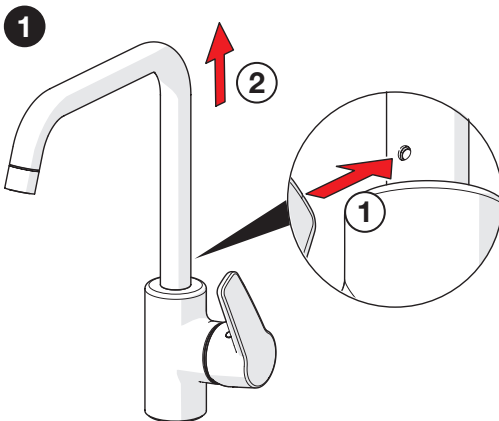
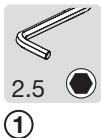
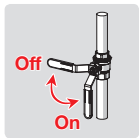

Cleaning the faucet

CZ Čištění baterie

DE Reinigung der Armatur

DK Rengøring af armaturet

ES Limpieza de la grifería

FI Puhdistus

FR Nettoyage du robinet

GR Καθαρισμός του βρύση

HU Takarítás a csapot

IT Pulizia della rubinetteria

NL Reinigen van de kraan

NO Rengjøring av kranen

PL Czyszczenie baterii

PT Limpeza da torneira

RU Чистка смесителя

SE Rengöring av blandarna

SK Čistenie vodovodnej batérie

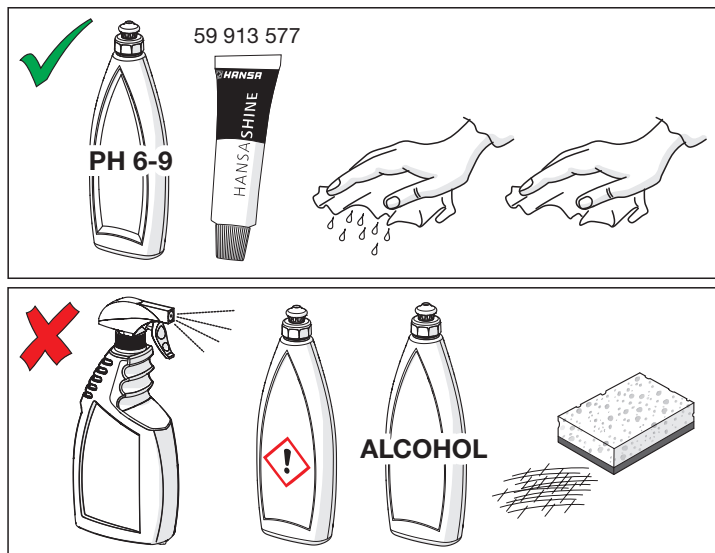

Cleaning/Changing the aerator

CZ Čištění/Výměna perlátoru

DE Reinigung/Wechseln des Luftsprudlers

DK Rensning/Udskiftning af perlator

ES Limpieza/Cambiar el aireador

FI Poresuuttimen puhdistaminen/vaihtaminen

FR Nettoyage/Changement de l'aérateur

GR Καθαρισμός/αλλαγή αεριστήρα

HU Az aerátor tisztítása/cseréje

IT Pulizia/Sostituzione dell'aeratore

NL Reinigen/veranderen van de perlator

NO Rensing/Bytting av strålesamler

PL Czyszczenie/Wymiana perlatora

PT Limpar/substituir o arejador

RU Очистка и замена аэратора

SE Rengöring/Byte av strålsamlare

SK Čistenie/Výměna perlátora

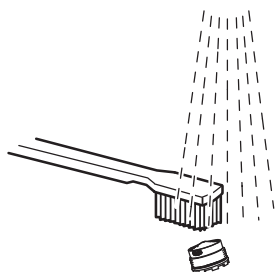

Spare parts

CZ Náhradní díly	FI Varaosat	NL Reserve-onderdelen	RU Запасные части
DE Ersatzteile	FR Pièces détachées	NO Reservedeler	SE Reservdeler
DK Reservedele	HU Alkatrészek	PL Części zamienne	SK Náhradné diely
ES Piezas de recambio	IT Pezzi di ricambio	PT Peças de reposição	

5148 2293, 5159 1193, 5148 2293 0037,
5148 2293 00676

- 1** 59 914 417
- 2** 59 912 504
- 3** 59 912 325
- 4** 59 912 111
- 5** 59 913 075
- 6** 59 914 432
- 7** 59 914 194 (**5148 2293, 5148 2293 00676**)
- 7** 59 902 692 (**5159 1193**)
- 7** 59 914 461 (**5148 2293 0037**)
- 8** 59 913 968
- 9** 59 914 437
- 10** 59 913 973
- 11** 59 912 474
- 12** 59 910 749
- 13** 59 910 008

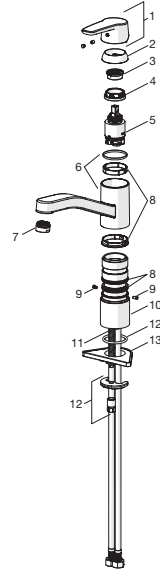

5266 2293

- 1** 59 914 417
- 2** 59 912 504
- 3** 59 912 325
- 4** 59 912 111
- 5** 59 913 075
- 6** 59 914 432
- 7** 59 914 194
- 8** 59 913 968
- 9** 59 914 437
- 10** 59 914 433
- 11** 59 914 434
- 12** 59 912 474
- 13** 59 910 749
- 14** 59 910 008

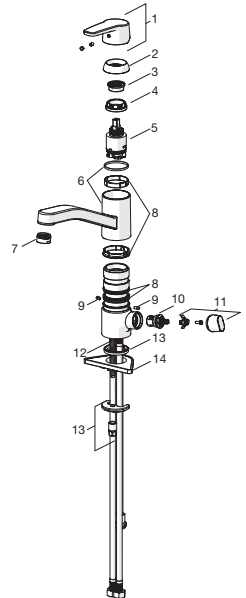

Spare parts

CZ Náhradní díly	FI Varaosat	NL Reserve-onderdelen	RU Запасные части
DE Ersatzteile	FR Pièces détachées	NO Reservedeler	SE Reservdelar
DK Reservedele	HU Alkatrészek	PL Części zamienne	SK Náhradné diely
ES Piezas de recambio	IT Pezzi di ricambio	PT Peças de reposição	

5156 2293, 5156 2293 0037

- 1 59 914 435
- 2 59 914 436 (5156 2293)
- 2 59 914 462 (5156 2293 0037)
- 3 59 914 429 (120°)
- 3 59 914 264 (60°/0°)
- 4 59 914 431
- 5 59 913 075
- 6 59 913 210
- 7 59 912 325
- 8 59 912 504
- 9 59 914 430
- 10 59 912 474
- 11 59 910 749
- 12 59 910 008

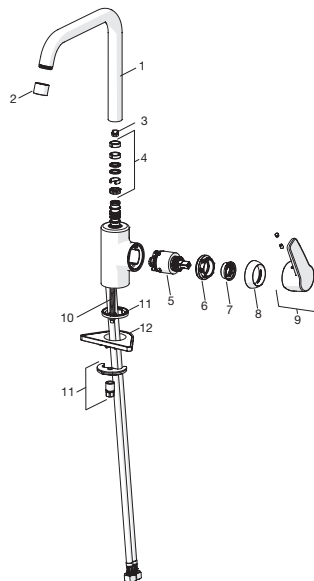

5160 2293

- 1 59 914 435
- 2 59 914 436
- 3 59 914 429 (120°)
- 3 59 914 264 (60°/0°)
- 4 59 914 431
- 5 59 913 075
- 6 59 913 210
- 7 59 912 325
- 8 59 912 504
- 9 59 914 430
- 10 59 914 433
- 11 59 914 434
- 12 59 912 474
- 13 59 910 749
- 14 59 910 008

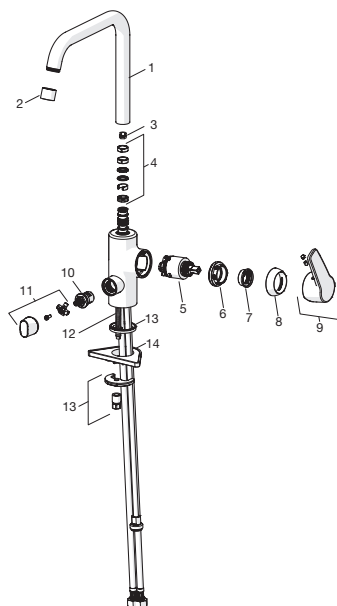

Spare parts

CZ Náhradní díly	FI Varaosat	NL Reserve-onderdelen	RU Запасные части
DE Ersatzteile	FR Pièces détachées	NO Reservedeler	SE Reservdelar
DK Reservedele	HU Alkatrészek	PL Części zamienne	SK Náhradné diely
ES Piezas de recambio	IT Pezzi di ricambio	PT Peças de reposição	

5270 2293

1	59 914 436
2	59 914 417
3	59 912 504
4	59 912 325
5	59 913 210
6	59 913 075
7	59 914 438
8	59 914 429 (120°)
8	59 914 264 (60°/0°)
9	59 914 266
10	59 912 474
11	59 910 749
12	59 910 008

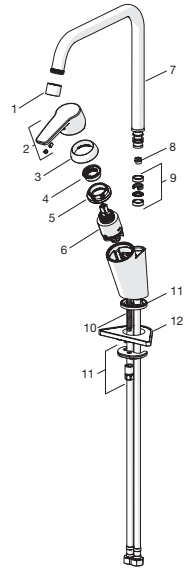

Oras Group is a powerful European provider of sanitary fittings: the market leader in the Nordics and a leading company in Continental Europe. The company's mission is to make the use of water easy and sustainable and its vision is to become the European leader of advanced sanitary fittings. Oras Group has two strong brands, Oras and Hansa.

The head office of the Group is located in Rauma, Finland, and the Group has four manufacturing sites: Burglengenfeld (Germany), Kralovice (Czech Republic), Olesno (Poland) and Rauma (Finland). Oras Group employs approximately 1400 people in twenty countries. Oras Group is owned by Oras Invest, a family company and an industrial owner.

HANSA Armaturen GmbH
P. O. BOX 81 02 40
D-70519 Stuttgart

Sigmaringer Strasse 107
D-70567 Stuttgart
Tel.: +49 711 16 14 0
Fax: +49 711 16 14 368
info@hansa.de

www.hansa.com



a member of orasgroup