

ATLANTIS 40[®]



Atex $\text{CE} \text{ } \text{II} \text{ } \text{2GD}^*$

* on request * auf Anfrage

art. B302 from DN 40 to DN 200 - GGG40 / 304 / NBR



| | |
|-----------|---|
| art. B302 | from DN 40 to DN 200 GGG40 / 304 / NBR |
| | |
| | |
| | |



| | |
|-----------|--|
| art. B322 | from DN 250 to DN 600 GGG40 / 304 / NBR |
| | |
| | |
| | |



| | |
|-----------|--|
| art. B306 | from DN 40 to DN 200 GGG40 / 316 / EPDM |
| art. B30A | from DN 40 to DN 200 GGG40 / GGG40 NICK / EPDM |
| art. B30E | from DN 40 to DN 200 GGG40 / GGG40 NICK / EPDM HT |
| art. B308 | from DN 40 to DN 200 GGG40 / 316 / VITON |



| | |
|-----------|---|
| art. B326 | from DN 250 to DN 600 GGG40 / 316 / EPDM |
| art. B32A | from DN 250 to DN 600 GGG40 / GGG40 NICK / EPDM |
| art. B32E | from DN 250 to DN 300 GGG40 / GGG40 NICK / EPDM HT |
| art. B328 | from DN 250 to DN 300 GGG40 / 316 / VITON |

MAIN STANDARD FEATURES:

CONSTRUCTION:

- **GENERAL SPECIFICATIONS:** BS EN 593 - (BS 5155) - MSS SP67 - API 609.
- **HOMOLOGATION:**
DVGW for GAS type-approvals according to UNI EN 13774
PN ≤16 DN40 - DN300
- **DIAMETERS:** DN40 - DN600.
- **CONNECTION WITH FLANGES UNI EN 1092:**
PN6 - PN10 - PN16 DN40 - DN300
PN6 - PN10 DN350 - DN600.
- **CONNECTION WITH FLANGES ANSI 150:**
DN40 - DN300.
- **MAXIMUM WORKING PRESSURE:**
PN16 DN40 - DN300 (for fluids)
PN16 DN40 - DN200 (for gas)
PN10 DN350 - DN600 (for fluids)
PN10 DN250 - DN600 (for gas).
- **TEMPERATURE LIMITS WITH SEALING SEATS IN:**
EPDM -20°C / +110°C for fluids
EPDM-HT -20°C / +130°C for fluids
NBR -20°C / +90°C for fluids
NBR -20°C / +60°C for gas
VITON -10°C / +160°C for fluids
VITON -10°C / +60°C for gas.
- **FACE TO FACE DIMENSIONS IN CONFORMITY WITH:**
BS EN 558 - ISO5752 - MSS SP67 - API609 - DIN3202/3-K1.
- **TOP FLANGE:** drilling ISO5211.
- **OPERATION DEVICE:** lever DN40 - DN200,
gear DN250 - DN600.
- **LOCKING DEVICE:** DN40 - DN200.
- Tested for vacuum at 900mbar.
- Polyurethane coating.
- **TESTS:** Hydraulic on body: 1,5 x nominal pressure
Hydraulic on sealing: 1,1 x nominal pressure
Pneumatic on sealing: 6bar.
- **NB:** for material compatibility please check the table with corrosion resistance at the end of the catalogue.

SPECIAL OPTIONS:

- Reduction gear with manual operation also for small DN.
- VITON seals.
- White EPDM.

ON REQUEST:

- Kit to convert from a manual valve to an actuated valve.
- For further special requests please consult our technical/commercial service.

ALLGEMEINE DATEN DER STANDARDAUSFÜHRUNG

BAUFORM:

- **ALLGEMEINE VORSCHRIFTEN:** BS EN 593 - (BS 5155) - MSS SP67 - API 609.
- **ZULASSUNG:**
DVGW für GAS laut UNI EN 13774
PN ≤16 DN40 - DN300
- **DURCHMESSER:** DN40 - DN600.
- **AUFFLANSCHBAR UNI EN 1092:**
PN6 - PN10 - PN16 DN40 - DN300
PN6 - PN10 DN350 - DN600.
- **AUFFLANSCHBAR ANSI 150:**
DN40 - DN300.
- **MAXIMALER BETRIEBSDRUCK:**
PN16 DN40 - DN300 (für Flüssigkeiten)
PN16 DN40 - DN200 (für Gas)
PN10 DN350 - DN600 (für Flüssigkeiten)
PN10 DN250 - DN600 (für Gas).
- **TEMPERATURBEREICH MIT DICHTUNGSSITZEN AUS:**
EPDM -20°C / +110°C für Flüssigkeiten
EPDM-HT -20°C / +130°C für Flüssigkeiten
NBR -20°C / +90°C für Flüssigkeiten
NBR -20°C / +60°C für Gas
VITON -10°C / +160°C für Flüssigkeiten
VITON -10°C / +60°C für Gas.
- **BAULÄNGEN IN ÜBEREINSTIMMUNG MIT:**
BS5155 - ISO5752 - MSS SP67 - API609 - DIN3202/3-K1.
- **OBERER FLANSCH:** mit Anschluss ISO5211.
- **BETÄTIGUNGSELEMENT:** Handhebel von DN40 - DN200,
Schneckengetriebe von DN250 - DN600.
- **VERRIEGELBARER HEBEL:** DN40 - DN200.
- Geeignet für Vakuum bis 900mbar.
- Polyurethanbeschichtung.
- **ABNAHMEPRÜFUNGEN:**
Wasserdruckprobe am Gehäuse: 1,5 x Nenndruck
Hydraulische Dichtheitsprüfung: 1,1 x Nenndruck
Pneumatische Dichtheitsprüfung: 6 bar.
- **NB:** Für die Werkstoffkompatibilität wird auf die Tabelle mit den Korrosionsbeständigkeitswerten am Ende des Katalogs verwiesen.

SONDERAUSFÜHRUNGEN:

- Schneckengetriebe mit Handbetätigung auch für kleine DN.
- Dichtungen aus VITON.
- EPDM weiß.

AUF ANFRAGE:

- Umbaukit von Rasthandhebel auf Klappe für Stellantriebe.
- Für weitere Sonderanfragen bitte unsere Vertriebsabteilung kontaktieren.

LIST OF VALVE COMPONENTS AND MATERIALS / TEILE- UND WERKSTOFFLISTE DES VENTILS ARTIKEL

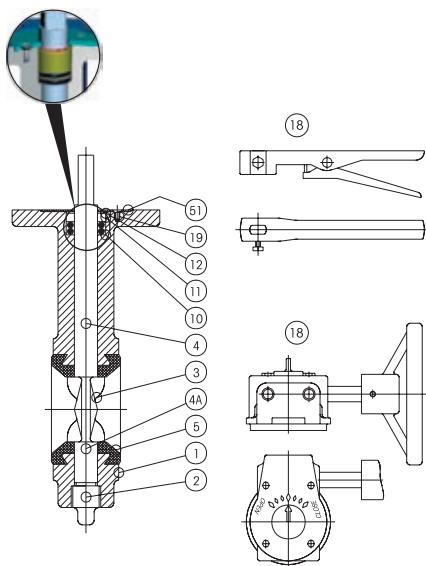

| REF. | PART. / TEIL | Q.TY MENGE | ARTICLES ARTIKEL | | | | | MATERIALS / WERKSTOFFE | | | | |
|------|--|---------------|---------------------------------|-----------|-----------|-----------|-----------|------------------------|------|------|------|------|
| | | | B302 | B306 | B30A | B30E | B308 | B322 | B326 | B32A | B32E | B328 |
| 1 | BODY / GEHÄUSE | 1 | GG40/ASTM A536 | | | | | | | | | |
| 2 | PLUG / VERSCHLUSS | 1 | C.S. NICK | C.S. NICK | C.S. NICK | C.S. NICK | C.S. NICK | | | | | |
| 3 | DISC / SCHEIBE | 1 | A304 | A316 | GGG40N | GGG40N | A316 | | | | | |
| 4 | SHAFT / WELLE | 1 | Type 410 | A316 | Type 410 | Type 410 | A316 | | | | | |
| 4A | LOWER SHAFT / UNTERWELLE | 1 | Type 410 | A316 | Type 410 | Type 410 | A316 | | | | | |
| 5 | SEAT / SITZRING | 1 | NBR | EPDM | EPDM | EPDM-HT | VITON | | | | | |
| 10 | UPPER SEAL / OBERE ABDICHTUNG | 2 | NBR | EPDM | EPDM | EPDM-HT | VITON | | | | | |
| 11 | BUSHING / STOPFBUCHSE | 1 | Delrin | Delrin | Delrin | Delrin | Delrin | | | | | |
| 12 | RING / RING | 1 | STEEL | STEEL | STEEL | STEEL | STEEL | | | | | |
| 19 | SCREW / SCHRAUBE | 2 | C.S. NICK | C.S. NICK | C.S. NICK | C.S. NICK | C.S. NICK | | | | | |
| 51 | WASHER / U-SCHEIBE | 1 | C.S. NICK | C.S. NICK | C.S. NICK | C.S. NICK | C.S. NICK | | | | | |
| 18 | LEVER HANDLE / HANDHEBEL | 1 | CARBON STEEL | | | | | | | | | |
| 18 | REDUCTION GEAR / SCHNECKENGETRIEBE MIT HANDRAD | 1 | CAST IRON GG25 / GUSSEISEN GG25 | | | | | | | | | |

SECTION / QUERSCHNITT

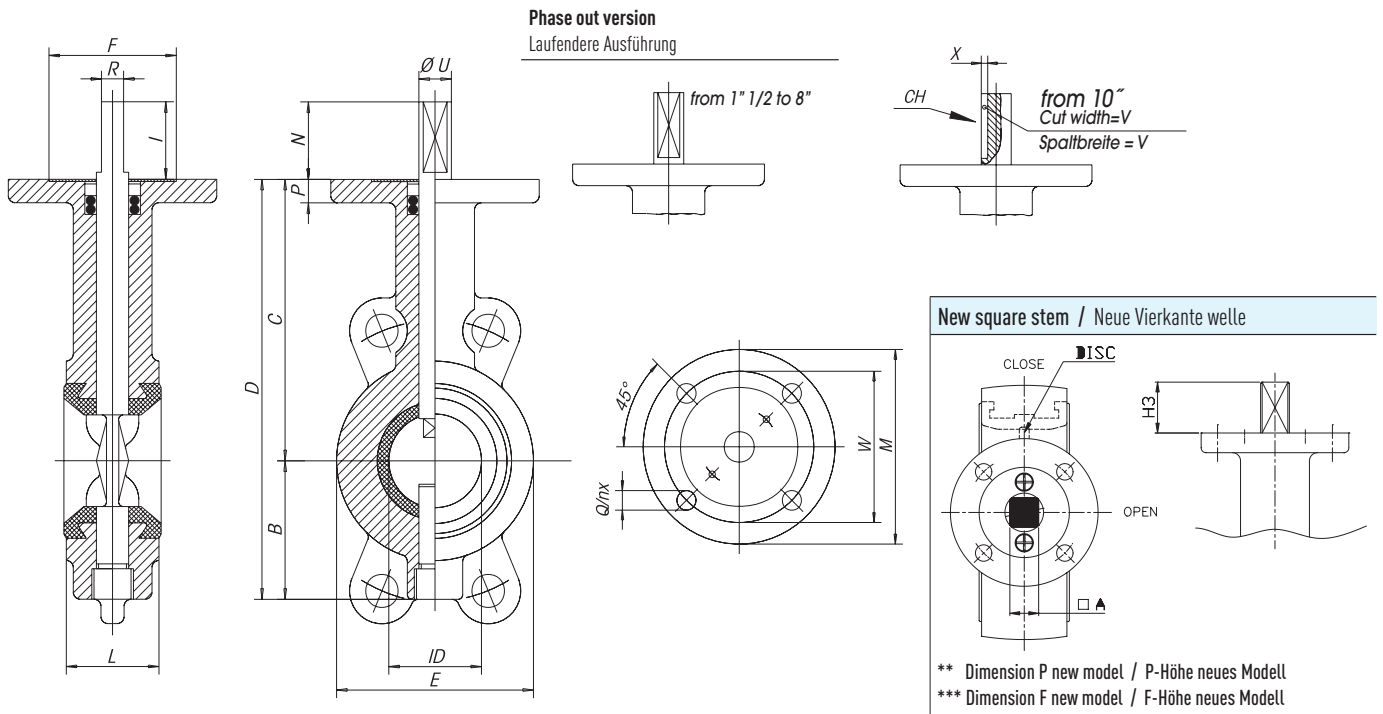

| SIZE | BODY / GEHÄUSE | | | | | | | | SHAFT / WELLE | | | | | | | | ISO5211 CONNECTION / ANSCHLUSS ISO 5211 | | | | | | | | * | |
|-------|----------------|-------|-----|-----|-----|-----|-----|-----|---------------|-----|----|------|----|----|----|-----|---|----------|-----|-----|-----|---|----|------|------|------|
| | ID | L | B | C | D | E | P | P** | N | I | R | ØU | H3 | □A | X | V | CH | ATT. ISO | M | W | n | Q | F | F*** | | KG |
| 1"1/2 | 40 | 40 | 40 | 59 | 120 | 179 | 85 | 10 | 12 | 33 | 30 | 9,5 | 14 | 33 | 11 | | | F07 | 90 | 70 | 4 | 9 | 55 | 55 | 2,7 | |
| 2" | 50 | 50 | 43 | 64 | 130 | 194 | 92 | 11 | 12 | 33 | 30 | 9,5 | 14 | 33 | 11 | | | F07 | 90 | 70 | 4 | 9 | 55 | 55 | 2,9 | |
| 2"1/2 | 65 | 63 | 46 | 72 | 137 | 209 | 107 | 11 | 12 | 33 | 30 | 9,5 | 14 | 33 | 11 | | | F07 | 90 | 70 | 4 | 9 | 55 | 55 | 4,1 | |
| 3" | 80 | 77 | 46 | 85 | 156 | 241 | 122 | 11 | 12 | 33 | 30 | 11,8 | 16 | 33 | 11 | | | F07 | 90 | 70 | 4 | 9 | 55 | 55 | 4,4 | |
| 4" | 100 | 100 | 52 | 95 | 170 | 265 | 150 | 11 | 12 | 33 | 30 | 11,8 | 16 | 33 | 11 | | | F07 | 90 | 70 | 4 | 9 | 55 | 55 | 4,7 | |
| 5" | 125 | 125 | 56 | 110 | 185 | 295 | 179 | 12 | 12 | 33 | 30 | 14,5 | 19 | 33 | 14 | | | F07 | 90 | 70 | 4 | 9 | 55 | 55 | 6,3 | |
| 6" | 150 | 147 | 56 | 123 | 203 | 326 | 206 | 12 | 12 | 33 | 30 | 14,5 | 19 | 33 | 14 | | | F07 | 90 | 70 | 4 | 9 | 55 | 55 | 7,9 | |
| 8" | 200 | 198 | 60 | 168 | 238 | 406 | 257 | 13 | 12 | 33 | 30 | 14,5 | 19 | 33 | 14 | | | F07 | 90 | 70 | 4 | 9 | 55 | 58 | 12,3 | |
| 10" | 250 | 244 | 68 | 203 | 270 | 473 | 316 | 15 | 16 | 65 | 60 | | 22 | 65 | 17 | 4 | 8 | 8x7 | F10 | 125 | 102 | 4 | 12 | 72 | 72 | 19,5 |
| 12" | 300 | 298 | 78 | 242 | 310 | 552 | 370 | 15 | 16 | 65 | 60 | | 28 | 65 | 22 | 4 | 8 | 8x7 | F10 | 125 | 102 | 4 | 12 | 72 | 72 | 30,5 |
| 14" | 350 | 352 | 78 | 290 | 330 | 620 | 410 | 15 | | 65 | 60 | | 28 | | | 4 | 8 | 8x7 | F10 | 125 | 102 | 4 | 12 | 72 | | 41 |
| 16" | 400 | 399,5 | 102 | 330 | 375 | 705 | 468 | 20 | | 75 | 70 | | 38 | | | 5 | 12 | 12x8 | F14 | 175 | 140 | 4 | 18 | 80 | | 62 |
| 20" | 500 | 493,5 | 127 | 400 | 440 | 840 | 578 | 20 | | 100 | 95 | | 45 | | | 5,5 | 14 | 14x9 | F16 | 210 | 165 | 4 | 22 | 90 | | 111 |
| 24" | 600 | 583 | 154 | 460 | 510 | 970 | 680 | 22 | | 100 | 95 | | 55 | | | 5,5 | 14 | 14x9 | F16 | 210 | 165 | 4 | 22 | 105 | | 210 |

* Weights refer to valve with bare shaft. / * Die Gewichte beziehen sich auf ein Ventil mit freier Achse.

| | SIZE | A | B | L | KG | |
|--|-------|-----|-----|----|-----|-----|
| | 1"1/2 | 40 | 9,5 | 29 | 265 | 0,6 |
| | 2" | 50 | 9,5 | 29 | 265 | 0,6 |
| | 2"1/2 | 65 | 9,5 | 29 | 265 | 0,6 |
| | 3" | 80 | 12 | 29 | 265 | 0,6 |
| | 4" | 100 | 12 | 29 | 265 | 0,6 |
| | 5" | 125 | 15 | 29 | 265 | 0,6 |
| | 6" | 150 | 15 | 29 | 265 | 0,6 |
| | 8" | 200 | 15 | 29 | 315 | 0,7 |

| | SIZE DN | COD. | | |
|--|---------|------|-----|---------|
| | 40 | 50 | 65 | RD1Y608 |
| | 80 | 100 | | RD1Y611 |
| | 125 | 150 | 200 | RD1Y613 |
| | 250 | | | RD1Y616 |
| | 300 | | | RD1Y617 |
| | 350 | | | RD1Y618 |
| | 400 | | | RD1Y619 |
| | 500 | | | RD1Y621 |
| | 600 | | | RD1Y622 |

NUTS AND STUD DIMENSIONS / ABMESSUNGEN BOLZEN UND ZUGSTANGEN

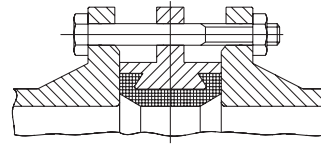
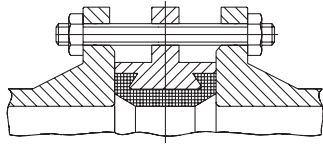

| SIZE | | PN10 | | PN16 | | ANSI150 | |
|-------|-----|---------|----|---------|----|------------------|----|
| | | Ø / L | N° | Ø / L | N° | Ø / L | N° |
| 1"1/2 | 40 | M16X110 | 4 | M16X110 | 4 | 1/2" X 4"5/16 | 4 |
| 2" | 50 | M16X130 | 4 | M16X130 | 4 | 5/8" X 5"1/8 | 4 |
| 2"1/2 | 65 | M16X130 | 4 | M16X130 | 4 | 5/8" X 5"1/8 | 4 |
| 3" | 80 | M16X140 | 8 | M16X140 | 8 | 5/8" X 5"1/2 | 4 |
| 4" | 100 | M16X150 | 8 | M16X150 | 8 | 5/8" X 5"1/2 | 8 |
| 5" | 125 | M16X150 | 8 | M16X150 | 8 | 3/4" X 6"3/8 | 8 |
| 6" | 150 | M20X160 | 8 | M20X160 | 8 | 3/4" X 6"3/8 | 8 |
| 8" | 200 | M20X170 | 8 | M20X170 | 12 | 3/4" X 6"1/4 | 8 |
| 10" | 250 | M20X180 | 12 | M24X190 | 12 | 7/8" X 7"1/2 | 12 |
| 12" | 300 | M20X190 | 12 | M24X200 | 12 | 7/8" X 8"3/8 | 12 |
| 14" | 350 | M20X190 | 16 | M24X220 | 16 | 1" X 8"3/4 | 12 |
| 16" | 400 | M24X230 | 16 | M27X240 | 16 | 1" X 10" | 16 |
| 20" | 500 | M24X250 | 20 | M30X280 | 20 | 1"1/8 X 12" | 20 |
| 24" | 600 | M24X300 | 20 | M33X300 | 20 | 1"1/4 X 13"13/16 | 20 |

| SIZE | | PN10 | | PN16 | | ANSI150 | |
|-------|-----|---------|----|---------|----|----------------|----|
| | | Ø / L | N° | Ø / L | N° | Ø / L | N° |
| 1"1/2 | 40 | M16X90 | 4 | M16X90 | 4 | 1/2" X 4"1/8 | 4 |
| 2" | 50 | M16X100 | 4 | M16X100 | 4 | 5/8" X 4"1/4 | 4 |
| 2"1/2 | 65 | M16X100 | 4 | M16X100 | 4 | 5/8" X 4"3/4 | 4 |
| 3" | 80 | M16X100 | 8 | M16X100 | 8 | 5/8" X 5" | 4 |
| 4" | 100 | M16X110 | 8 | M16X110 | 8 | 5/8" X 5"1/4 | 8 |
| 5" | 125 | M16X120 | 8 | M16X120 | 8 | 3/4" X 5"1/2 | 8 |
| 6" | 150 | M20X120 | 8 | M20X120 | 8 | 3/4" X 5"1/2 | 8 |
| 8" | 200 | M20X130 | 8 | M20X130 | 12 | 3/4" X 6" | 8 |
| 10" | 250 | M20X140 | 12 | M24X150 | 12 | 7/8" X 6"1/2 | 12 |
| 12" | 300 | M20X160 | 12 | M24X160 | 12 | 7/8" X 7"1/4 | 12 |
| 14" | 350 | M20X160 | 16 | M24X170 | 16 | 1" X 8" | 12 |
| 16" | 400 | M24X190 | 16 | M27X200 | 16 | 1" X 8"3/4 | 16 |
| 20" | 500 | M24X200 | 20 | M30X230 | 20 | 1"1/8 X 10"1/2 | 20 |
| 24" | 600 | M24X260 | 20 | M33X270 | 20 | 1"1/4 X 12" | 20 |

BREAKAWAY TORQUES in Nm / ANLAUFMOMENTE (LOSBRECHMOMENT) in Nm

| PN - bar | DN size | 40 | 50 | 65 | 80 | 100 | 125 | 150 | 200 | 250 | 300 | 350 | 400 | 500 | 600 |
|----------|---------|-------|----|-------|----|-----|-----|-----|-----|-----|-----|-----|-----|------|------|
| | | 1"1/2 | 2" | 2"1/2 | 3" | 4" | 5" | 6" | 8" | 10" | 12" | 14" | 16" | 20" | 24" |
| 0 | | 11 | 14 | 18 | 27 | 40 | 59 | 88 | 157 | 248 | 343 | 485 | 662 | 1142 | 2385 |
| 6 | | 11 | 20 | 25 | 32 | 41 | 62 | 92 | 173 | 275 | 382 | 549 | 766 | 1327 | 2787 |
| 10 | | 12 | 23 | 27 | 34 | 54 | 71 | 106 | 186 | 321 | 551 | 680 | 882 | 1634 | 3250 |
| 16 | | 14 | 25 | 29 | 37 | 56 | 86 | 123 | 262 | 392 | 576 | | | | |

The values in Nm may vary as a function of the seals material, temperature and type of medium. For a firm operation of the various types of actuators, in the different working conditions it is necessary to consider a safety factor of 1,5.

Die Nm-Werte sind abhängig von dem Material der Sitzringe, der Temperatur und Art von Flüssigkeit. Für die Gewährleistung der Funktionssicherheit der verschiedenen Arten von Servosteuerung unter verschiedenen Einsatzbedingungen ist ein Sicherheitsfaktor von = 1,5 zu berücksichtigen.

Kv AND Cv VALUES AS A FUNCTION OF OPENING ANGLE / Kv- UND Cv-WERTE IN ABHÄNGIGKEIT DES ÖFFNUNGSWINKELS

| SIZE | | Kv AND Cv VALUES AS A FUNCTION OF OPENING ANGLE / Kv- UND Cv-WERTE IN ABHÄNGIGKEIT DES ÖFFNUNGSWINKELS | | | | | | | | | | | | | | | |
|-------|-----|--|------|------|------|------|------|------|------|-------|-------|-------|-------|-------|-------|-------|-------|
| | | 20° | | 30° | | 40° | | 50° | | 60° | | 70° | | 80° | | 90° | |
| | | ID | L | B | C | D | E | P | N | I | R | U | X | V | Z1 | Z2 | Z3 |
| 1"1/2 | 40 | 2,6 | 3 | 4,3 | 5 | 9,5 | 11 | 16 | 18 | 22 | 26 | 39 | 45 | 60 | 70 | 69 | 80 |
| 2" | 50 | 6,7 | 8 | 7,8 | 9 | 16 | 18 | 24 | 28 | 48 | 55 | 62 | 72 | 95 | 110 | 116 | 135 |
| 2"1/2 | 65 | 8,6 | 10 | 13 | 15 | 23 | 27 | 38 | 44 | 73 | 85 | 95 | 110 | 145 | 168 | 181 | 210 |
| 3" | 80 | 13 | 15 | 20 | 23 | 34 | 39 | 56 | 65 | 112 | 130 | 142 | 165 | 216 | 250 | 267 | 310 |
| 4" | 100 | 23 | 27 | 35 | 41 | 61 | 71 | 99 | 115 | 198 | 230 | 259 | 300 | 401 | 465 | 466 | 540 |
| 5" | 125 | 50 | 58 | 74 | 86 | 129 | 150 | 211 | 245 | 414 | 480 | 526 | 610 | 845 | 980 | 948 | 1100 |
| 6" | 150 | 83 | 96 | 121 | 140 | 211 | 245 | 345 | 400 | 677 | 785 | 871 | 1010 | 1392 | 1615 | 1647 | 1910 |
| 8" | 200 | 142 | 165 | 211 | 245 | 354 | 410 | 591 | 685 | 1099 | 1275 | 1478 | 1715 | 2302 | 2670 | 2746 | 3185 |
| 10" | 250 | 220 | 255 | 328 | 380 | 560 | 650 | 974 | 1130 | 1810 | 2100 | 2328 | 2700 | 3664 | 4250 | 4224 | 4900 |
| 12" | 300 | 319 | 370 | 466 | 540 | 819 | 950 | 1353 | 1570 | 2629 | 3050 | 3405 | 3950 | 5129 | 5950 | 6336 | 7350 |
| 14" | 350 | 388 | 450 | 647 | 750 | 1120 | 1300 | 1905 | 2210 | 3517 | 4080 | 4836 | 5610 | 6964 | 8078 | 9655 | 11200 |
| 16" | 400 | 552 | 640 | 776 | 900 | 1483 | 1720 | 2405 | 2790 | 4310 | 5000 | 6336 | 7650 | 9284 | 10770 | 11121 | 12900 |
| 20" | 500 | 785 | 910 | 1375 | 1595 | 2457 | 2850 | 3991 | 4630 | 7414 | 8600 | 9914 | 11500 | 15121 | 17540 | 19310 | 22400 |
| 24" | 600 | 1078 | 1250 | 1974 | 2290 | 3448 | 4000 | 5250 | 6090 | 10776 | 12500 | 14224 | 16500 | 20336 | 23590 | 24397 | 28300 |